

FILE



EDOARDO WEBER

FABBRICA ITALIANA CARBURATORI
BOLOGNA

MASTER CATALOG

TECHNICAL INTRODUCTION



EDOARDO WEBER

FABBRICA ITALIANA CARBURATORI
BOLOGNA

MASTER CATALOG

TECHNICAL INTRODUCTION

This technical introduction is intended to describe in a plain and simple form the operating principles of carburetors in general and of Weber carburetors in detail, with the aim of rendering the functional and constructional solutions contained in the Catalog more readily understandable.

It also purports to be a guide for automotive engineers, to make them familiar with the different carburetors manufactured by Weber: this should facilitate the task of the designer in the selection of the type of carburetor most suitable to his design requirement and of carburetor servicemen in their tune-up and maintenance work.

CARBURETOR OPERATION PRINCIPLES

DIAGRAMMATIC ILLUSTRATION OF FUEL SYSTEM

An example of the type of fuel system generally adopted on internal combustion engines is diagrammatically shown in Fig. 1 where the feed stages are:

- a) **air feed:** air is generally admitted through a filter (or cleaner) mounted on the carburetor air horn; in some cases the filter is differently located and ducted to carburetor.
- b) **fuel feed:** the delivery of fuel from tank to carburetor is generally handled by a diaphragm pump, mechanically driven by the camshaft.
- c) **mixture blending:** the preparation and feed of the air/fuel mixture, in the blend and quantity required for satisfactory engine operation, are handled by the carburetor.
- d) **delivery of fuel mixture to cylinders:** by proper ducting in cylinder head or by **intake manifolds** mounted on engine.

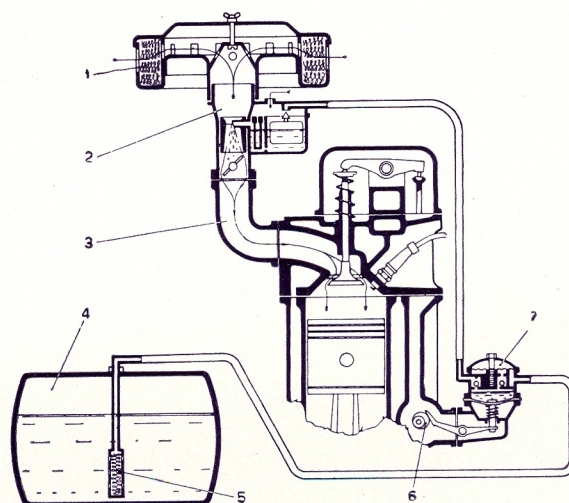

Fig. 1

1. Air cleaner - 2. Carburetor - 3. Intake manifold - 4. Fuel tank - 5. Fuel filter - 6. Camshaft - 7. Diaphragm pump.

FUNDAMENTAL TYPES OF CARBURETORS

Before going into the details of carburetion it is advisable to consider first the constructional and design features of the more commonly used carburetors — Fig. 2.

A) **Vertical carburetor:** the barrel, where metering and adjustment devices are located, is vertical and flow runs from the bottom upwards; it is seldom used at present, except in some industrial vehicle applications.

B) **Downdraft carburetor:** the barrel is vertical and flow runs from the top downwards; it is the type most commonly applied on modern mass-produced automobiles.

C) **Horizontal carburetor:** barrel and flow are horizontal; mainly used on sports cars and on industrial and agricultural engines.

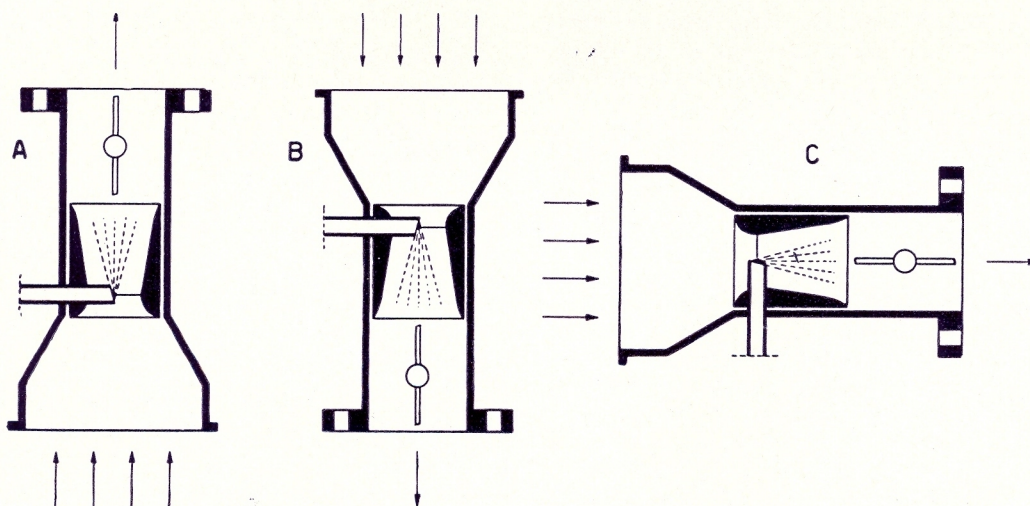

Fig. 2

Vertical - B Downdraft - C Horizontal.

CONDITIONS OF ENGINE OPERATION

The conditions of I. C. engine operation are most diversified as a result of vehicle service requirements. As we all know, the road speed of the vehicle is controlled by the driver through the accelerator pedal. The engine operating conditions are determined in this way and may be:

- **at full power**, viz., total admission of the mixture and full use of engine output (accelerator fully depressed and throttle in carburetor fully open);
- **at part load**, viz., partial admission of fuel mixture and max output of engine not required (accelerator lightly pressed and throttle in carburetor partly open);
- **at idle speed**, viz., throttle in carburetor almost totally closed as occurs with engine running and vehicle at a standstill;
- **during pick-up or acceleration**, viz., when engine speed is increased, more or less rapidly depending on the position given to the accelerator pedal.

Pick-up operation is a transitory stage of engine operation that calls for particular devices in carburetor, which will be discussed later together with other devices.

TASK OF CARBURETOR - FUEL MIXTURE

The carburetor is a device intended to blend air and fuel and send the mixture to the cylinders in the correct proportions to assure good engine performance under the different conditions of operation. The fuel mixture supplied by the carburetor must meet **dosage** and **homogeneity** requirements: when these are not satisfied it is not possible to obtain smooth and proper engine operation under all service conditions.

— **Dosage**: by the term dosage, or **mixture titer** α is intended the ratio between the weight of the air and the fuel simultaneously drawn by the engine. Considering currently marketed gasolines as mixtures of saturated hydrocarbons, on the basis of their chemical composition we may infer that to fully burn one kilogram of fuel an average of $3\frac{1}{2}$ kg of oxygen is required; since the oxygen contained in the air reaches a percentage in weight of about 23% we may come to the theoretical conclusion that about 15 kg of air are needed for the complete combustion of one kg of gasoline. We may hence say that the **theoretical** or **stoichiometric** value of the **mixture ratio** is approximately 15 (obtained from the chemical composition of gasoline) while the combustion range limits are from about 6 to 22: this means that with values α lower than 6 (excess gasoline) or greater than 22 (excess air) combustion is practically impossible. The combustible mixture can then be considered well-proportioned when the mixture ratio is of 15 parts air to one part gasoline. If the amount of air is lower, that is, the gasoline content is greater than the theoretical amount, the resulting mixture is said to be **rich** or **strong** whereas it is called **lean** or **weak** when the gasoline content is smaller than the theoretical amount.

A well-adjusted carburetor must, therefore, supply a fuel mixture adequately proportioned to meet all engine speed and load requirements, in order to ensure best possible performance both from the standpoint of power output and economical operation: **For the sake of simplification, it is assumed that the mixture blend α should be constant for every condition of engine operation.**

— **Homogeneity**: To obtain optimum combustion and, consequently, best engine operation with regard to power output as well as fuel economy, besides being correctly blended the combustible mixture must also be as homogeneous as possible, that is, the fuel and air must form an intimate blend. This facilitates fuel vaporization and minimizes the risks of condensed fuel on carburetor duct and intake manifold walls which would lead to defective feed to engine cylinders. Many means have been devised and introduced to facilitate mixture homogeneity and favor evaporation of the fuel: generally, the intake manifold is either heated by hot water recirculated from the cooling system or by contact in a given area (**Hot spot**) with the exhaust manifold.

THE SIMPLE CARBURETOR

It is proposed now to devote some space to consideration of the more elementary carburetion devices - **simple carburetors** as they are termed - and then gradually describe the more complex modern carburetors.

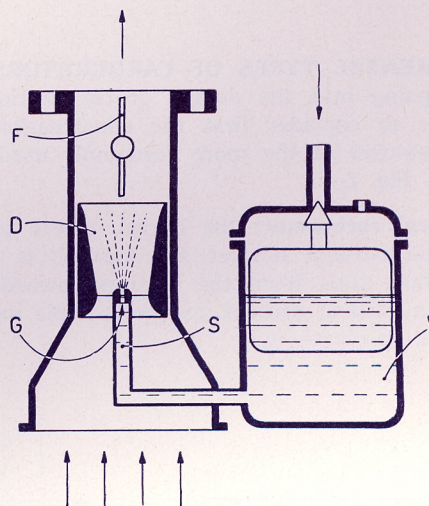

Fig. 3

D Venturi - F Throttle - G Main jet - S Spray tube - V Bowl.

The **simple carburetor** - Fig. 3 - consists of:

- a **fuel bowl V**, where the fuel coming from the main tank is kept at a constant and pre-determined level by suitably designed devices;
- a **Venturi D**;
- a **spray tube S** through which fuel is drawn, during operation, from bowl V through calibrated orifice G;
- a **throttle valve F**, generally of the butterfly type, located in the air horn downstream of main jet and tube S, which regulates the amount of air/fuel mixture drawn in by the engine.

Before going into the operation details of the simple carburetor, let us consider the function of its components.

— **Bowl V** communicates with the surrounding atmosphere through its upper end and contains a float system designed to maintain the fuel in the float chamber always at the same level, regardless of engine operating conditions, by opening or closing the fuel inlet through a **needle valve**.

When the level tends to fall, after the engine has drawn some of the fuel, the float drops and thereby opens the needle valve, admitting more fuel. When fuel has again reached normal level, the float is lifted and the needle valve shuts off the fuel inlet. The level of fuel in the float chamber is not quite level horizontally with the top of the jet in spray tube **S**, so as to prevent fuel leakage in the carburetor when the engine is inoperative. However, when the pressure in the carburetion area becomes lower than the pressure in the float chamber, fuel is «sucked» out of the main jet in the Venturi.

— **Venturi D**, which may be thought of as two truncated cones joined base-to-base at their narrower ends. When air flows through the Venturi, its speed gradually varies and reaches its peak in the area where the section is smallest. It is possible to demonstrate how in the constriction of a duct where a fluid flows at its fastest rate (on account of the reduced section) pressure is lower than in the other, larger sections.

Having established this fact, and considering that Venturi **D** is the smallest section in the carburetor air horn and that at its free end the carburetor pressure is atmospheric, it will be easy to understand why a pressure lower than atmospheric, viz., a vacuum, is promoted in the restriction of the Venturi just where the max. speed of air is found.

— **Spray tube S**, which carries the fuel correctly metered by calibrated orifice **G** - whose size is accurately determined and checked - to the center of the restriction in Venturi **D**.

By increasing or decreasing the diameter of this metering orifice, the mixture supplied by the carburetor becomes richer or leaner because more or less fuel is drawn in by the engine.

— **a throttle F**, to regulate the amount of mixture drawn by the engine, generally of the butterfly valve type and consisting of a rotatable disc or plate controlled through a suitably designed lever and rod linkage by the accelerator pedal. In other cases, particularly in motor-cycle carburetors, the throttle may be a cylindrical valve or a flat gate valve.

Operation of the simple carburetor

With engine running, an air flow is promoted in the carburetor by the intake strokes of the pistons in the cylinders; as described earlier, a vacuum will develop in the restriction of Venturi **D**.

To make this clearer, suppose we place a series of pressure gauges **M** along the carburetor throat while the engine is running at wide-open throttle: the liquid in the graduated tubes of the gauges

will undergo some displacements - the higher the vacuum at the point where the gauges are inserted, the higher will the liquid level rise — **Fig. 4** —. Whether the engine speed is increased or decreased, the strongest vacuum will always be found in the Venturi restriction.

The above is also true when the engine is running at part-open throttle: in fact, when the section of the passage is reduced by closing throttle **F** the amount of aspirated air decreases considerably but the highest vacuum in the zone immediately below the throttle, that is, where fuel is sprayed into the air stream, will always be in the Venturi restriction.

The operation of the carburetor is hence intuitive: the vacuum promoted by engine suction in the restriction of Venturi **D** (where spray tube **S** is located) acts on the fuel in bowl **V** whose pressure is atmospheric and, because of the pressure differential, fuel will issue through calibrated orifice **G**. On account of this vacuum-promoted suction, fuel is forced out of orifice **G** at a very high speed and mixes with the air stream: part of the fuel vaporizes and part is atomized into very fine droplets that mingle with the air.

While flowing along the carburetor throat and

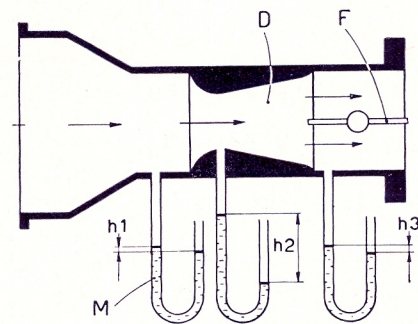

Fig. 4

D Venturi - **F** Throttle - **M** Pressure gauges.

past the intake manifold, most of the tiny droplets vaporize and form a still more intimate blend with the air: this further vaporization is promoted in part by the vacuum and, in many cases, by the temperature at which the intake manifold is kept.

The restriction in the Venturi is essential to promote a vacuum sufficient to draw enough fuel when air capacity is low, as is the case at low engine speeds with wide-open throttle and under part-open throttle operation: however, this restriction must never be such as to cause excessive volumetric efficiency losses, namely, undercharge of cylinders with a consequent drop in power output at low engine r.p.m. rates with wide-open throttle.

Considerations on simple carburetor operation

A perfect carburetor should supply a combustible mixture having a practically constant ratio, regardless of the r.p.m. and load conditions of the engine. Instead, a simple carburetor of the type so far examined incorporates the fundamental shortcoming of supplying an air fuel mixture whose ratio is not constant but dependent upon engine r.p.m. and load conditions.

If one consider the physical laws governing the efflux of fluids (both liquid and gaseous) from restricted apertures it then becomes easy to demonstrate that, as the vacuum in the Venturi increases the amount of fuel issuing from the jet will also increase, but at a faster rate than the increase in the incoming air.

Hence, the mixture supplied by the simple carburetor becomes sensibly richer as the engine is revved up: it follows that though being correctly proportioned at maximum engine r.p.m. the mixture is poor when r.p.m. is low.

The simple carburetor, as considered here, besides being unable to supply a constant-ratio mixture does not allow:

- engine operation under no-load conditions, that is, it does not have an **idling speed device**;
- cold starting of the engine, particularly at low seasonal temperatures, that is, it does not incorporate a **starting device (choke)**;
- the sudden variation of engine r.p.m. rates: in other words, it is not equipped with any sort of **progression hole system or acceleration devices**.

The above shortcomings serve to stress the reasons why it became necessary to develop a carburetor incorporating all these devices and capable of supplying a correctly proportioned mixture.

THE MODERN CARBURETOR

AUTOMATIC CONTROL OF THE AIR/FUEL

MIXTURE RATIO

As mentioned in an earlier paragraph, the simple carburetor has his fundamental drawback in mixture supply: the higher the vacuum acting on the spray tube the richer the air/fuel blend.

We are thus faced with the problem of correcting the ratio of the mixture supplied by the carburetor in order that it be near-constant for any condition over the engine operation range.

Another requirement is that this correction must be automatic, that is, it must be obtained without the assistance of any externally-controlled mechanical element.

Air correction

The type of mixture ratio control adopted on Weber carburetors is the so-called **air corrector system**: in this case - **Fig. 5** - main jet **G** opens into a well **P** which communicates with the fuel duct through spray tube (commonly termed nozzle) **S** and, with the atmosphere, through the metered jet **Gf** and the lateral holes in emulsion tube **T** located in the well.

When the vacuum in Venturi **D** is transmitted to well **P** through nozzle **S**, fuel is drawn via jet **G** while outside air, via jet **Gf**, comes in through the lateral holes in emulsion tube **T**.

As the vacuum becomes stronger, following an increase in engine speed, the fuel coming out of jet **G** is corrected by the increasingly higher «braking» action of the air drawn in through jet **Gf** and the holes in emulsion tube **T**: in a well-adjusted carburetor, that is, one where jets **G** and **Gf** and tube **T** are suitably dimensioned, we can obtain a supply of fuel having a constant mixture ratio for any and all of the engine operating conditions.

This is a fully automatic correction inasmuch as there is no concurrence of externally-operated mechanical adjustment devices, whether for fuel or air capacities, to vary the ratio of the mixture.

An added advantage of the air corrector system is that it favours the atomization of fuel in the engine-aspirated air stream because the effluent sprayed through nozzle **S** is already a part-mixture formed by the air drawn in via jet **Gf** and the fuel coming from jet **G**.

The dimensions of nozzle **S** and the space between

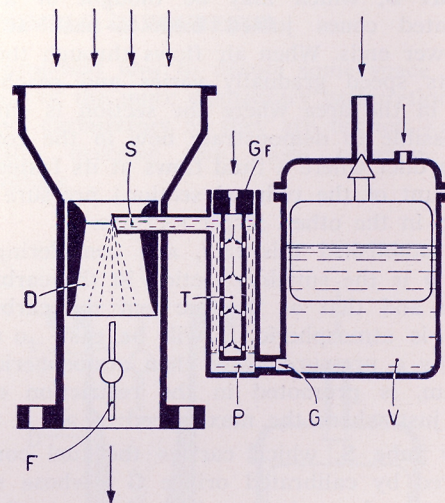

Fig. 5

D Venturi - F Throttle - G Main jet - Gf Air corrector jet - P Well - S Spray nozzle - T Emulsion tube - V Bowl.

tube **T** and well (where fuel flows) are also of great importance in obtaining the desired mixture correction: in fact, the reduced size of nozzle **S** and of the clearance around the emulsion tube **T** constitutes a stronger resistance to the passage of the mixture the higher the flow, that is, the higher the vacuum in the Venturi, the higher the resistance.

By varying these two design features the fuel supply curve can be corrected and the best possible mixture for proper engine feed can thus be obtained.

It should be noted that, if necessary, with the air correction system a mixture enrichment or leaning can generally be accomplished - either with high engine r.p.m. and wide-open throttle or with low r.p.m. and part-open throttle - by suitably dimensioning the diameters of main jet **G**, air corrector jet **Gf**, emulsion tube **T** and nozzle **S**.

SLOW RUNNING OR IDLING SPEED DEVICE

The simple carburetor, though adequate in supplying the mixture as described previously, is not complete to supply engine with fuel as required by any service condition. As an example, let us consider an **idling engine**: in this case, since the vehicle is at a standstill or no gear is engaged, the engine runs at a low r.p.m. rate to develop just the power required to overcome the passive resistance of the moving parts. Under these conditions, the throttle must be nearly closed: it follows that the degree of vacuum developed in the Venturi is not sufficient to force out any fuel through the nozzle on account of the small quantity of air drawn in by the engine. It would then be impossible to obtain a true idle speed operation with a simple carburetor of the type described: and that is why the carburetor must embody a device capable of handling this task.

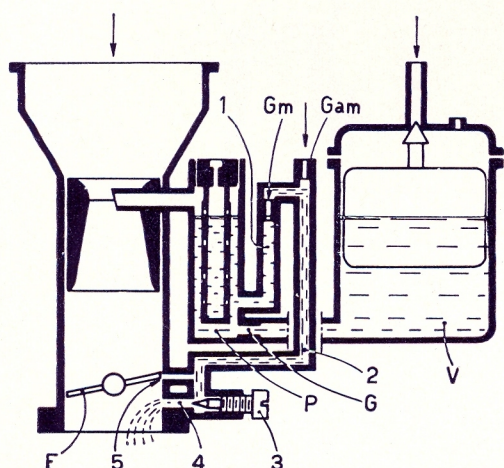

Fig. 6

F Throttle - G Main jet - Gm Idle speed jet - Gam Idle speed air jet - P Well - V Bowl - 1. Idle speed jet-to-well duct - 2. Idle speed mixture duct - 3. Idle speed mixture set screw - 4. Idle speed orifice - 5. Transition orifice.

The idling speed device consists of a small auxiliary carburetor incorporated in the carburetor proper and, in the more common type - see Fig. 6 - it takes its fuel supply downstream of main jet G. However, in other designs it may take the fuel directly from the bowl and operate as a truly independent unit having only the bowl in common with the main carburetor.

The metered idle speed jet Gm communicates with well P through duct 1 and with the carburetor throat downstream of throttle F via duct 2 and metered orifice 4, the latter being adjustable by means of a taper point screw 3; duct 2 is open to the atmosphere through jet Gam.

The vacuum promoted by the engine at idle speed sucks in fuel through jet Gm and air through jet Gam: the mixture thus obtained passes into the carburetor throat downstream of throttle F via duct 2 and orifice 4.

By suitably turning in or out a slow running adjusting screw on the throttle F opening the engine revs may be varied during idle operation. Through the taper point screw 3, on the other hand, the mixture may be adjusted to the more suitable ratio for a given throttle setting.

CHANGE-OVER FROM IDLE SPEED TO POWER OPERATION

Progressive acceleration

As described so far, the carburetor can operate equally well at idle speed and normal speed, with part or wide-open throttle.

However, if an attempt is made to change-over from idling speed to full power operation by opening the throttle, the engine cannot pick up speed and stalls. This inefficient period is generally called a «flat-spot».

During idle speed operation, the engine receives a correctly proportioned air/fuel mixture; but when the throttle is suddenly opened, the vacuum directly beneath it drops and, consequently, also the amount of fuel supplied by the idle speed circuit decreases whereas, at the same time, the air drawn in across the wider throttle gap increases. The result is an excessively lean mixture because, at this particular throttle setting, the vacuum acting on nozzle S is no longer sufficient to force out any fuel through the main jet: at this point the engine is «starved» and stops.

To avoid «flat-spots», i.e., the lack of a **progressive action during acceleration**, a transition orifice 5 is drilled in the carburetor, directly in line with the upper edge of the throttle in the no-load position and communicating with idle speed mixture duct 2 — Fig. 7.

During idle speed operation — **diagram A, Fig. 7** — air is introduced into the carburetor barrel through transition orifice 5: this air blends with the mixture issuing from idle speed duct 2 because the transition orifice is located upstream of the throttle valve where pressure is almost the same as atmospheric.

When the throttle opening is increased — **diagram B, Fig. 7** — transition orifice 5 will be located in a zone downstream of the throttle, where the vacuum is rather high, and will supply the mixture in parallel with idle speed orifice 4: the amount of fuel sprayed by orifices 4 and 5 is sufficient to maintain the correct mixture ratio until the time when spray nozzle S takes over.

If at this point the throttle is opened some more, orifices 4 and 5 will no longer supply a sufficient amount of mixture: at the same time, however, the vacuum in the Venturi has increased to the point where spray nozzle S is called upon to spray fuel drawn from the bowl through main jet G — **diagram C, Fig. 7**.

In some cases there are two transition orifices: one in line with the upper edge of the part-open throttle and the other just a bit lower.

This particular arrangement is designed to extend the transition time while the throttle is in the opening stage.

During these progressive acceleration stages, especially when the throttle is opened suddenly the shape and size of emulsion tube **T** become two extremely important factors: in fact, in tube **T** and in well **P** there is a certain amount of fuel whose level — with engine idling — is almost the same as the one in bowl. When the throttle is opened for the change-over from idle speed to rated speed operation, as soon as even a slight vacuum is developed around the spray nozzle, the fuel in tube **T** and in well **P** is immediately drawn by the engine into the carburetor barrel. This will compensate for the leanness of the mixture which would otherwise take place on account of the higher inertia of the liquid; the latter promotes a delay in the supply of fuel with respect to the air

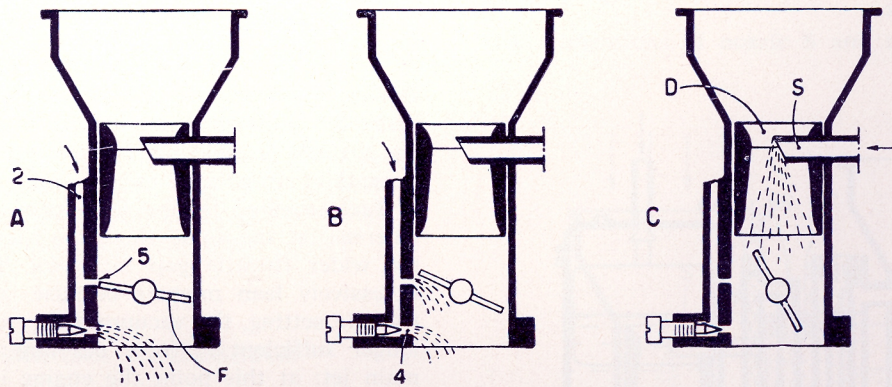

Fig. 7

D Venturi - F Throttle - S Nozzle - 2. Idle speed duct - 4. Idle speed orifice - 5. Transition orifice

which, instead, is ready to stream out even if the vacuum is very low or instantaneously promoted. We may then conclude that there are two methods generally adopted to ensure smooth engine operation during throttle opening:

- the **transition orifice or orifices**, that « follow » throttle opening and compensate for the reduced supply through the idle speed orifice;
- the **reserve** of fuel in well **P** and in tube **T** which the engine can draw upon even if the vacuum is slight as a consequence of the lower engine r.p.m.;
- in this manner the engine operates smoothly also in the transitory stage represented by the change-over from idle speed to power speed operation until the r.p.m. rate becomes sufficient to force out fuel in the normal way through the spray nozzle in the Venturi.

ACCELERATING PUMP

In spite of the design features described in the previous paragraph, and particularly when Venturi diameters are large, it may happen that during the sudden opening of the throttle the engine shows a hesitation in picking up which causes flat-spots in carburetion.

A remedy for this trouble is the adoption of an **accelerating pump** which injects an additional amount of fuel into the carburetor throat when the throttle is opened, thus compensating for the weakening of the mixture resulting from the above-mentioned causes. This makes a smooth increase in engine angular speed possible.

As incorporated in Weber carburetors — **Fig. 8** — the accelerating pump generally consists of a plunger **3**, sliding in a barrel machined in the carburetor body and controlled, through rod **1**, by lever **4** secured to the throttle shaft.

When throttle **F** is closed, lever **4** lifts plunger **3**, through rod **1**, and the plunger compresses spring **2** so that an amount of fuel equivalent to the volume swept by the plunger is sucked from bowl **V** into the cylindrical cavity,

When the throttle is opened, rod **1** is inactive and

spring **2** pushes down the plunger: the fuel in the pump is then forced out reaches the carburetion area through a delivery duct and a metered jet **Gp**. Ball valves **Va** and **Vm** are placed in the suction duct from bowl **V** and the delivery duct to jet **Gp** respectively.

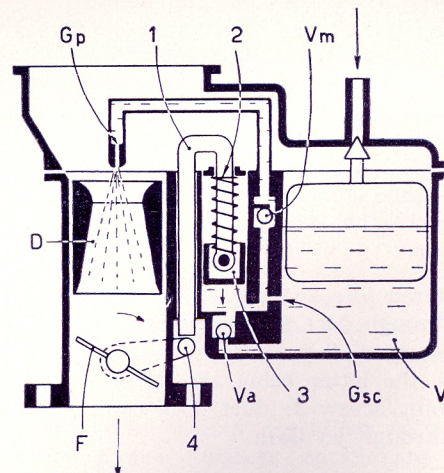

Fig. 8

D Venturi - F Throttle - **Gp** Accelerating pump jet - **Gsc** Accelerating pump drain jet - **V** Bowl - **Va** Inlet valve - **Vm** Delivery valve - 1. Pump rod - 2. Spring - 3. Pump plunger - 4. Pump control lever.

- When plunger 3 moves up, inlet valve **Va** opens and allows the passage of fuel, while valve **Vm** closes and shuts off the flow of air to the pump through jet **Gp**.
- When plunger 3 moves down, valve **Vm** opens while valve **Va** closes and shuts off the passage of fuel.

However, considering that the same type of carburetor may be fitted on a number of differently designed engines it becomes necessary, in some cases, to vary the amount of fuel supplied by the accelerating pump: to this end, metered drain jet **Gsc** is incorporated to allow, during the pump delivery stage, the return to the bowl of part of the fuel accumulated during the inlet stage.

A second possible way of varying the amount of fuel supplied by the accelerating pump is to shorten or lengthen rod 1, and hence the stroke of plunger 3: in this case, the amount of fuel available in the pump is respectively reduced or increased.

STARTING DEVICE

Notwithstanding all the improvements mentioned, a carburetor designed in accordance with the previous descriptions will still be faulty in that it does not permit engine cold starts, especially at very low ambient temperatures.

Phenomena which take place during cold starts are:

- the **vacuum** acting on jets is too weak, since the starter-cranked engine, before running smoothly and regularly, turns at a very low r.p.m. owing to the low starter motor speed as well as to the high passive resistance caused by the high viscosity of the lubricant which is still cold.
- the **mixture supplied** by the idle speed jet is inadequate and no mixture issues through the main jet, because of the low engine r.p.m. rate.
- the **condensation** of most of the fuel supplied by jets on the walls of inlet ducts. This is due both to the low vacuum and low temperature in the ducting: cylinders receive an excessively lean air/fuel mixture charge. This still holds true even if the carburetor supplies a normally proportioned mixture inasmuch as the condensed fuel will arrive at the cylinders in a liquid state and, as such, will be discharged through the exhaust system without taking any part in the combustion process.

It then becomes necessary to fit the carburetor with a specially designed device which will solve the cold starting faults successfully.

Starting device of the auxiliary carburetor type

This device consists of an auxiliary carburetor embodied in the main carburetor — **Fig. 9** — and is made up of a **reserve well 4**, having an adequate capacity and open to the atmosphere, which is in communication with bowl **W** at one end (via starting jet

Gs) and with the area downstream of the throttle at the other end (via duct 1 and driver-controlled valve 3).

When starting is attempted, a vacuum is promoted by the starter-cranked engine downstream of throttle **F** (which must be kept in the idle speed position).

This vacuum forces fuel out of well 4, jet **Gs** and its housing, and into the fuel feed ducting: part of this fuel will evaporate and blend with the air coming from jet 2 and the gap around the throttle, to form a mixture having a ratio sufficient to permit engine starting. Once the engine is started, it will run at a sufficiently high r.p.m. rate: as a result, vacuum increases and improvements follow in the vaporization of fuel which the pump still supplies in amounts sufficient to compensate for the condensation losses.

By continuing its operation, the engine warms up and the oil becomes more fluid, thus reducing mechanical resistance losses; also the inlet duct walls warm up and minimize fuel condensation: at this point, the starting device must be shut off as the mixture supplied has grown to be too rich since the engine has in the meantime reached a temperature sufficient to operate smoothly with the normal carburetion devices.

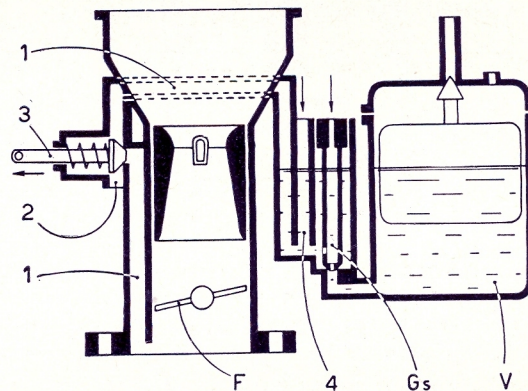

Fig. 9

F Throttle - **Gs** Starting jet - **V** Bowl - **1**. Starting mixture duct - **2**. Starting air jet - **3**. Starting valve - **4**. Well, starting fuel reserve.

This form of **starting device of the simple blanking valve type**, however, has two drawbacks:

- It must be fully inserted at the moment starting is attempted, even if the engine temperature is not too low: the result is an excessively rich mixture.
- It supplies a mixture constant in amount and richness, even during engine warm up: the result is a fuel consumption not justified by functional requirements which will continue until the device is switched off at the end of the warm up period.

To overcome these difficulties, designers have adopted **progressive-action starting devices** whose main feature is that they can be inserted either partially or totally, according to engine temperature, thus supplying a mixture the amount and ratio of which are dependent on the extent to which the device is inserted.

Starting device of the choke valve type

A second commonly adopted type of starting device consists of a **butterfly choke valve** (strangler) — **Fig. 10** — placed in the carburetor throat, upstream of Venturi **D**: upon starting — **diagram A** — choke valve **F_s** is moved to the fully closed position while throttle valve **F** is opened slightly by the driver or by a direct linkage to the choke valve: under these conditions, the suction of the starter-cranked engine promotes a vacuum around the nozzle **S** sufficient to force out the fuel required for engine starting.

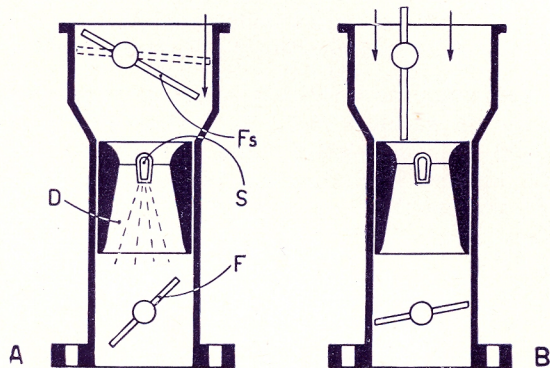

Fig. 10

D Venturi - F Throttle - F_s Choke - S Spray nozzle.

Once the engine is started up, the vacuum on spray nozzle **S** increases and, consequently, a wider opening of the choke valve becomes necessary to prevent flooding of the engine. By adjusting the opening of choke valve **F_s** it is thus possible to accomplish prompt starts as well as correct operation of the engine during warm up: after operating temperature is reached, the choke is fully opened — **diagram B**. The opening of choke **F_s** to obtain a weakening of the mixture with engine started may either be controlled by the driver through a suitable linkage or, better still, automatically. In the latter case — **Fig. 10** — choke valve **F_s** is mounted freely and eccentrically on its shaft and is held in the closed position by a suitable loaded spring: the increased vacuum pro-

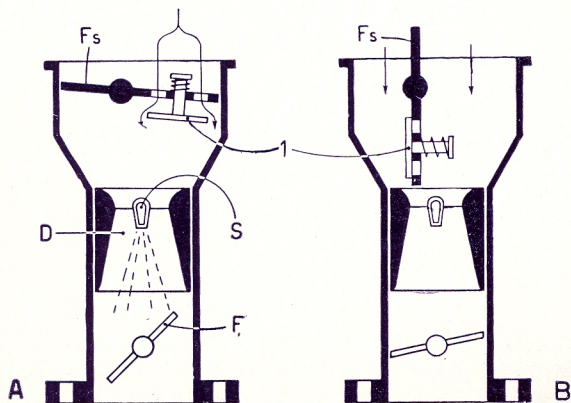

Fig. 11

D Venturi - F Throttle - F_s Choke valve - S Spray nozzle - 1. Automatic valve.

motored by the engine after starting determines the opening of the choke valve by overcoming the resistance of its springs. This leans out mixture strength during starts.

In another design — **Fig. 11** — the weakening of the mixture is obtained by an automatic valve **1** mounted on choke **F_s** which, in this case remains closed — **diagram A** —: valve **1** automatically opens under the action of the increased vacuum promoted by the engine once it is started. When the rated operation temperature is reached, this type of choke is also fully open — **diagram B**.

AUTOMATIC STARTING DEVICE

In modern carburetors the air choke is automatically operated to relieve the driver of responsibility and, also, to prevent the possibility of misuse, or of oversight to move the control out of action once the engine is operating at the rated temperature.

This automatic control is generally obtained by a thermo-sensitive element (bi-metal spiral lamina or thermostat capsules) which, when the engine is cold, takes care of inserting the starting device by opening the auxiliary carburetor valve or closing the choke, as the case may be.

The thermo-sensitive element is generally actuated by exhaust-heated air, or by water derived from the engine cooling system. As the engine temperature increases after starting, the thermostatic control is deformed more and more until it excludes the starting device.

When stopped, the engine cools down and, consequently, also the thermostatic control loses heat thus slowly resuming its original shape: when it does, the starting device is again inserted.

MODERN CARBURETOR FEATURES

In the previous paragraphs we have considered and described the basic carburetor devices but some space should also be devoted to a few very particular devices which have been developed to meet the ever-new and stringent requirements of modern automotive engineering.

Auxiliary (or secondary) Venturi

To improve functional characteristics, Weber carburetors have been fitted with a second Venturi, **C**, called **auxiliary** or **secondary**, smaller and narrower than the main or primary Venturi, **D**. The two Venturis are concentrically mounted and the auxiliary Venturi terminates exactly where the section of the main Venturi is narrowest. — **Fig. 12**.

The auxiliary Venturi is designed to give a more « homogeneous » blend of fuel and engine-aspirated air and to bring the mixture so obtained to the center of the constriction of Venturi **D**. The advantage of this arrangement is a more balanced and uniform distribution of fuel engine cylinders.

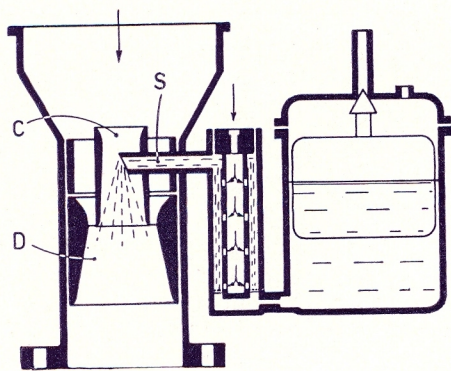

Fig. 12

C Auxiliary Venturi - D Main Venturi - S Spray nozzle.

Full-power device

For some particular operational requirement, the carburetor may be provided with a **full-power device** — Fig. 13 — consisting of jet **G_{pp}** in parallel with main jet **G** and communicating with bowl **V** through the accelerating pump cylinder and valve **V_p**, located in the cylinder itself.

With open throttle, the pump plunger moves down, valve **V_p** opens and fuel — metered by jet **G_{pp}** — may flow from the pump cylinder to well **P** together with the fuel supplied by the main jet. With closed or part-open throttle, the pump plunger is lifted and valve **V_p** closes: under these conditions, the engine is fed only through main jet **G**.

By suitably selecting the diameters of jets **G** and **G_{pp}** it is possible to obtain the supply of a correct-strength mixture during wide-open throttle operation (**full-power**) and of a leaner mixture during part-open throttle operation (**economy**). In the latter case fuel consumption is cut because jet **G_{pp}** is excluded from the circuit.

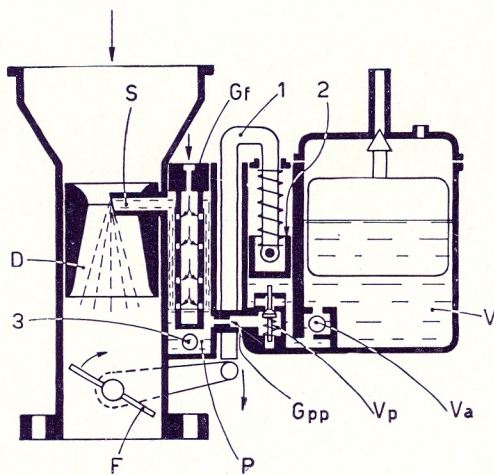

Fig. 13

D Venturi - F Throttle - Gf Air corrector jet - G_{pp} Full power jet - P Well - S Spray nozzle - V Bowl - Va Inlet valve - Vp Full power valve - 1. Pump control rod - 2. Pump plunger - 3. Duct, main jet-to-well.

In other designs, the inclusion or exclusion of full-power jet **G_{pp}** is obtained by means of a valve, automatically controlled by a diaphragm, under the action of the vacuum present downstream of the throttle.

CARBURETORS WITH TWO OR MORE THROATS

To improve power performance of engines, the trend in automotive design is to adopt more than one carburetor on the same engine (multiple carburetor system) so that each carburetor feeds a given group of cylinders, or even just one cylinder as in the case of sports and racing cars; in this way, volumetric efficiency is improved and the fuel feed to each cylinder, or group of cylinders, is unaffected by the intake stroke of the others, with the advantage of a more uniform mixture distribution.

To this same end, a number of carburetors having just one inlet duct (**single-throat**) could also be used but, for evident reasons of simplicity and positive control, preference is given to the **dual or multi-**

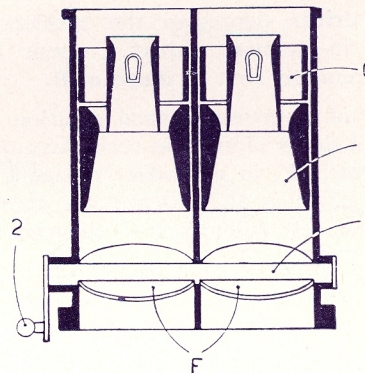

Fig. 14

C Auxiliary Venturi - D Primary Venturi - F Throttles - 1. Shaft, throttles - 2. Throttles control lever.

throat carburetors whose main characteristic is that they consist of two or more complete, single-throat carburetors in the form of a single unit and having a common constant-level float chamber and bowl. These carburetors may be of the two-, three-, or four-barrel type and of the downdraft, horizontal or vertical design, their main feature being the throttle-opening control which may be either of the **synchronized** or **differential** type.

The **synchronized**, or **simultaneous**, opening of the throttles can be obtained by fitting the throttles on a single shaft, as shown in Fig. 14 where a downdraft dual carburetor is illustrated, or by pairing the two throttle shafts by means of two equal-radius toothed sectors as in the downdraft dual-throat carburetor shown in Fig. 15.

The synchronized control is generally adopted when each carburetor barrel feeds fuel to one separate cylinder or a group of cylinders, independently of the others; why throttles must open in accordance with the same law to obtain the identical degree of fuel feed in each and every cylinder is self-explanatory.

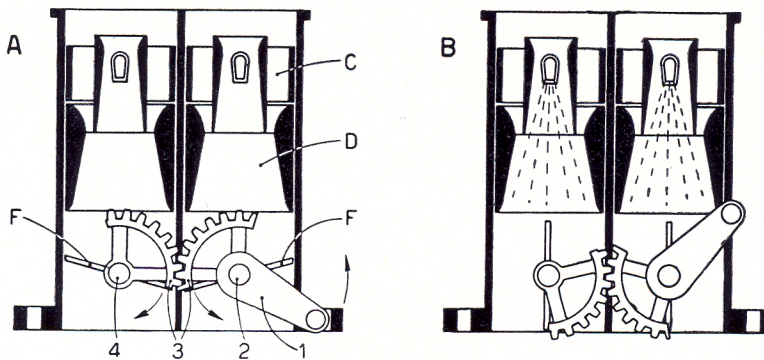

Fig. 15

C Auxiliary Venturi - D Main Venturi - F Throttles - 1. Throttles control lever - 2. Throttle shaft - 3. Throttles control toothed sectors - 4. Throttle shaft.

The **differential opening** of the throttles, on the other hand, is incorporated when it is desired to obtain from the engine a high power performance at a high r.p.m. rate and a smooth « progression » in low-r.p.m. acceleration. In this case, as shown by the down-draft dual-throat carburetor of Fig. 16, the two throttle shafts 4 and 7 are interconnected by a suitable unequal-radius toothed sector linkage.

When the driver depresses the accelerator pedal, throttle F_1 in **primary** throat 1 opens first while throttle F_2 remains shut — **diagram B**.

At the end of a pre-established rotation angle, primary shaft 4 drags along also secondary shaft 7 thus opening throttle F_2 in **secondary** throat 8: when the accelerator pedal is fully depressed, both throttles are simultaneously fully open — **diagram C**.

The primary throat system allows smooth and progressive acceleration and economical operation when the maximum power is not demanded of the engine, while the secondary throat system provides the maximum power performance of the engine.

It goes without saying that in this case both the primary and secondary throats are ducted to a common chamber 9 whence manifold passages carry the mixture to the engine cylinders.

SELECTING A CARBURETOR

Weber carburetors are identified by a designation number, an example of which is:

32 IM

where the number indicates the diameter of the throat (or throats) in millimeters while the letter suffixes defines the type.

To assist designers and fitters in the selection of the desired type of carburetor, here is an approximate formula used to determine the throat diameter needed:

$$D = 0,8 \div 0,9 \sqrt{\frac{V \times n}{i}} \text{ in mm.}$$

where:

V = total cylinder displacement, in liters,

i = number of cylinders in the engine,

n = max. speed rate, in r.p.m.

This formula holds true even in the case of installations requiring one or more multi-throat carburetors, each throat of which feeds one cylinder, or a group of cylinders, independently of the others.

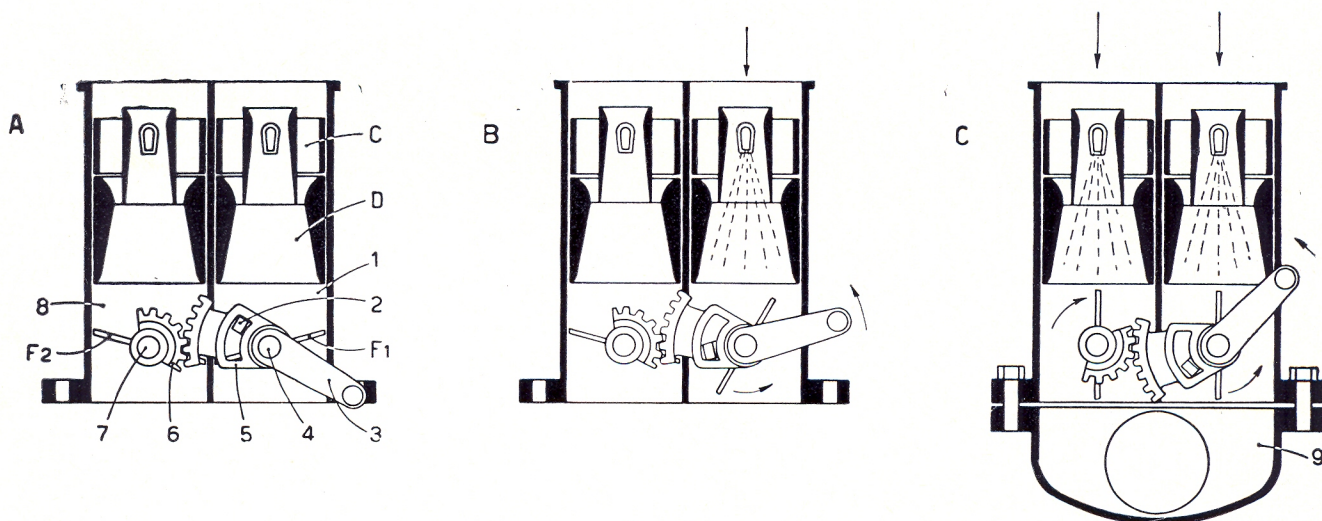

Fig. 16

C Auxiliary Venturi - D Main Venturi - F₁ Primary throttle - F₂ Secondary throttle - 1. Primary throat - 2. Lug - 3. Throttles control lever - 4. Primary shaft - 5. Primary toothed sector (idle) - 6. Secondary toothed sector - 7. Secondary shaft - 8. Secondary throat - 9. Chamber in intake manifold.

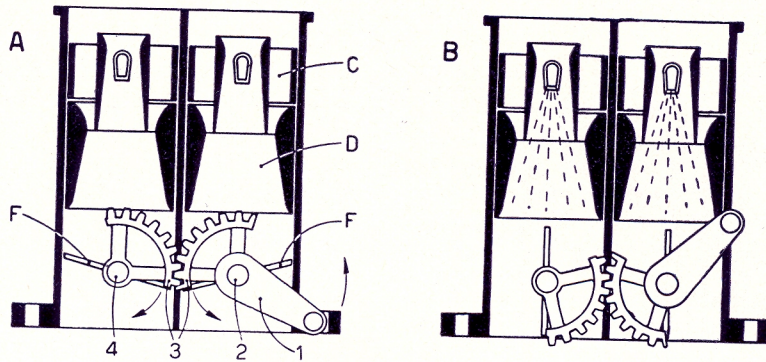

Fig. 15

C Auxiliary Venturi - D Main Venturi - F Throttles - 1. Throttles control lever - 2. Throttle shaft - 3. Throttles control toothed sectors - 4. Throttle shaft.

The **differential opening** of the throttles, on the other hand, is incorporated when it is desired to obtain from the engine a high power performance at a high r.p.m. rate and a smooth « progression » in low-r.p.m. acceleration. In this case, as shown by the down-draft dual-throat carburetor of Fig. 16, the two throttle shafts 4 and 7 are interconnected by a suitable unequal-radius toothed sector linkage.

When the driver depresses the accelerator pedal, throttle **F₁** in **primary** throat 1 opens first while throttle **F₂** remains shut — **diagram B**.

At the end of a pre-established rotation angle, primary shaft 4 drags along also secondary shaft 7 thus opening throttle **F₂** in **secondary** throat 8: when the accelerator pedal is fully depressed, both throttles are simultaneously fully open — **diagram C**.

The primary throat system allows smooth and progressive acceleration and economical operation when the maximum power is not demanded of the engine, while the secondary throat system provides the maximum power performance of the engine.

It goes without saying that in this case both the primary and secondary throats are ducted to a common chamber 9 whence manifold passages carry the mixture to the engine cylinders.

SELECTING A CARBURETOR

Weber carburetors are identified by a designation number, an example of which is:

32 IM

where the number indicates the diameter of the throat (or throats) in millimeters while the letter suffixes defines the type.

To assist designers and fitters in the selection of the desired type of carburetor, here is an approximate formula used to determine the throat diameter needed:

$$D = 0,8 \div 0,9 \sqrt{\frac{V \times n}{i}} \text{ in mm.}$$

where:

V = total cylinder displacement, in liters,

i = number of cylinders in the engine,

n = max. speed rate, in r.p.m.

This formula holds true even in the case of installations requiring one or more multi-throat carburetors, each throat of which feeds one cylinder, or a group of cylinders, independently of the others.

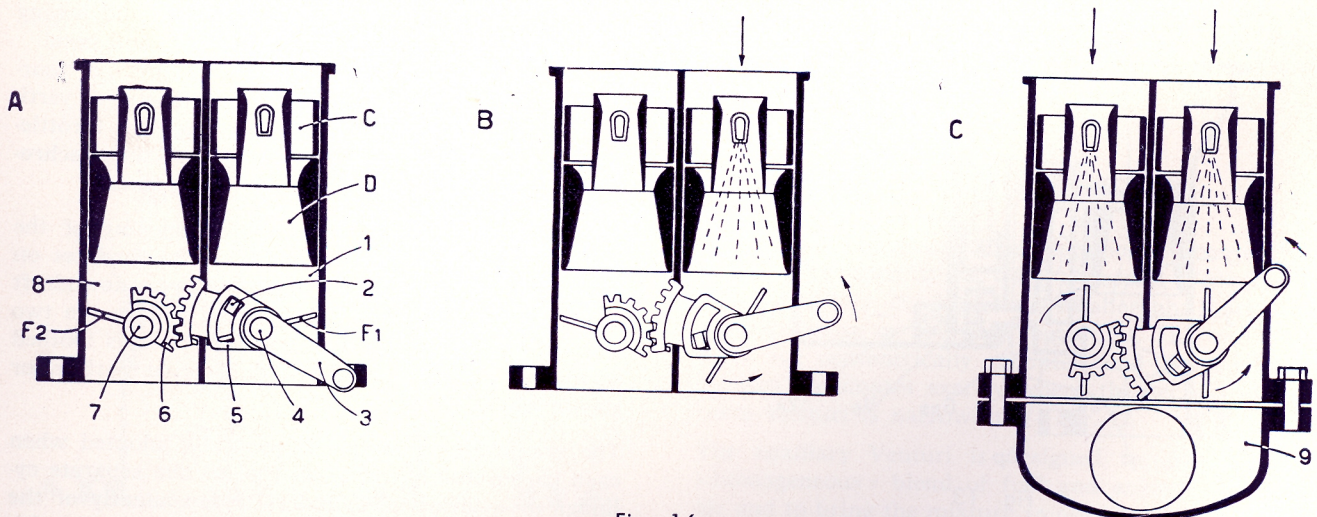

Fig. 16

C Auxiliary Venturi - D Main Venturi - F₁ Primary throttle - F₂ Secondary throttle - 1. Primary throat - 2. Lug - 3. Throttles control lever - 4. Primary shaft - 5. Primary toothed sector (idle) - 6. Secondary toothed sector - 7. Secondary shaft - 8. Secondary throat - 9. Chamber in intake manifold.

EXAMPLES OF APPLICATION

A few indicative diagrams are given below to show some possible applications of Weber carburetors on different types of engines. In this connection it is important to stress the fact

that, to prevent fuel feed troubles during acceleration or deceleration, carburetors are installed with the bowl turned toward the direction of vehicle forward travel.

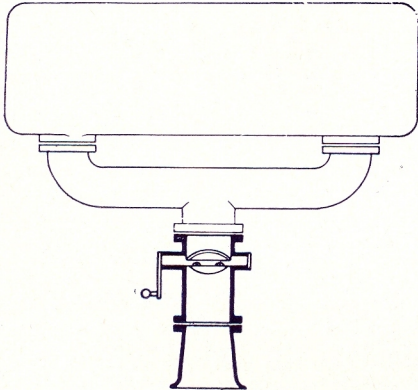

Fig. 17

Horizontal single-throat carburetor, mounted on an in-line engine.

To prevent uneven distribution of fuel charge to the different cylinders, the throttle shaft must be horizontal.

Downdraft single-throat carburetor, mounted on an apposed-cylinder engine.

To prevent uneven distribution of fuel charge to the different cylinders, the throttle shaft must be parallel to the cylinder longitudinal axis.

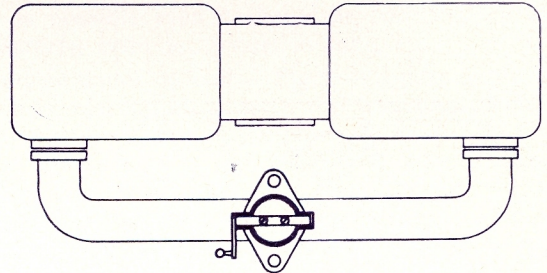

Fig. 18

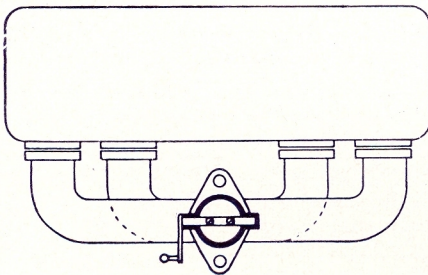

Fig. 19

Downdraft single-throat carburetor, mounted on an in-line engine.

To prevent uneven distribution of fuel charge to the different cylinders, the throttle shaft must be parallel to the engine longitudinal axis.

Downdraft dual-throat carburetor, with synchronized control of throttles, mounted on a V-type engine.

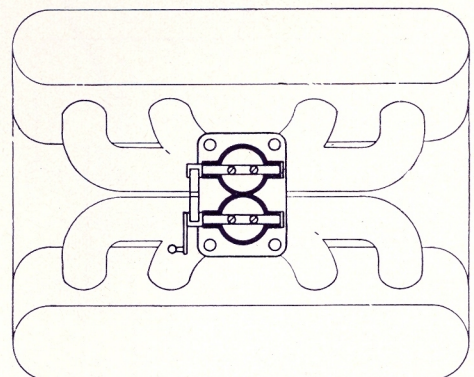

Fig. 20

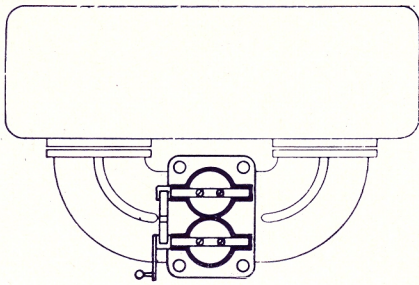

Fig. 21

Downdraft dual-throat carburetor, with synchronized control of throttles, mounted on an in-line engine.

Downdraft dual-throat carburetors, with single throttle-shaft, mounted on an in-line engine.

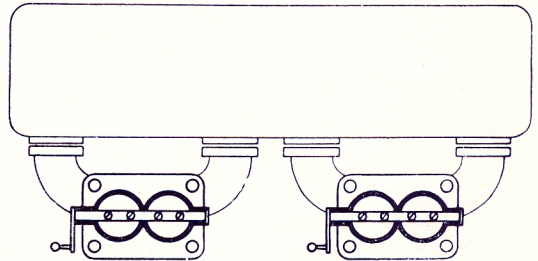

Fig. 22

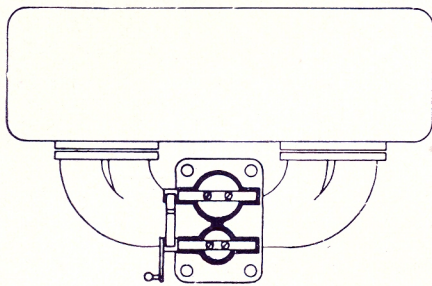

Fig. 23

Downdraft dual-throat carburetor, with differential control of the throttles, mounted on an in-line engine.

In this particular installation, both carburetor throats must end in the same chamber whence fuel is ducted to cylinders.

Downdraft four-throat carburetor, mounted on a V-type engine.

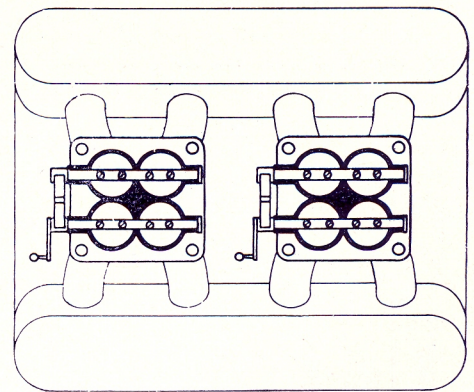

Fig. 24

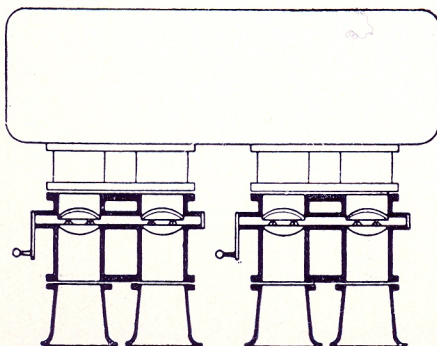

Fig. 25

Horizontal dual-throat carburetors, mounted on an in-line engine

CONSTRUCTIONAL FEATURES OF CARBURETORS

BASIC CARBURETOR DEVICES

In this section the carburetor will be divided in its essential parts which will be discussed separately and in detail to give the servicemen who will be called upon to repair the carburetor a chance to evaluate in full the functional importance of each of its constituent parts.

Basically, the carburetor consists of:

- 1) Idle speed and progression circuit
- 2) Main fuel feed circuit
- 3) Starting device or starter.

It is important to point out that a normally adjusted carburetor represents a compromise solution which on the whole meets the requirements of the engine. When any of its factory-set adjustments are modified, its functionality will inevitably be upset to a degree seldom justified by the improvements sought.

For instance, sometimes it is possible to increase the top speed of a car by fitting a larger-diameter Venturi and a suitable main jet: in this case, however, it will be found that slow running operation is slightly worsened.

Before any such modification, one should first consider if the desired improvement justifies the consequent faulty performance. This example confirms the above outlined assertion that a well-adjusted carburetor is invariably the best possible compromise between pick-up performance, fuel consumption and vehicle speed.

When an engine **idles**, that is, the car is at a standstill and engine turns over at around **450-600 r.p.m.**, the vacuum promoted under these conditions in the Venturi area is too weak to draw out any mixture through the spray nozzle, but this is handled by a small independent carburetor whose task is to give the engine a mixture in the amount and strength required to ensure smooth engine operation at low rotational speeds, at the same time developing just the power needed to overcome the resistance of the moving parts.

As a matter of fact, the three basic elements into which carburetors were divided in a previous paragraph are actually three complete and independent carburetors sharing in common a constant-level bowl for their fuel supply.

This usually holds true even when — as will be outlined later — the idle speed circuit does not derive its fuel supply directly from the bowl but from a well.

It then follows that the **starting device** makes engine starts possible when climatic conditions would otherwise give rise to starting difficulties, the **idle speed circuit** permits no-load operation and the **main feed circuit** allows the attainment of all the performances that a car is expected to give under normal service conditions. Therefore, when the engine operates in the conditions illustrated in **A, Fig. 1 (no-load)**, only one of the three carburetors mentioned above is operative and yet is so self-sufficient that smooth operation is possible even without the contribution of the Venturis, main jet, emulsion tube, etc.

With engine under **no-load** — **Fig. 1** — a gear engaged and the accelerator depressed, the **transition orifice** comes into play and « progressively follows » the engine — **diagram B** — until spray nozzle **S** takes over — **diagram C**.

Each of the three small carburetors considered has a specific task within well-defined limits: if one retards or advances its function engine operation will be irregular. This is why the tuning of a carburetor consists in synchronizing the three components.

1) IDLE SPEED AND PROGRESSION CIRCUIT

Considering that obtain the desired smoothness of engine operation at idle speed and during progressive acceleration the supply of an air/fuel mixture of suitable strength is an essential condition, it follows that the carburetor must necessarily incorporate one calibrated jet — **idle speed jet** — to meter the fuel

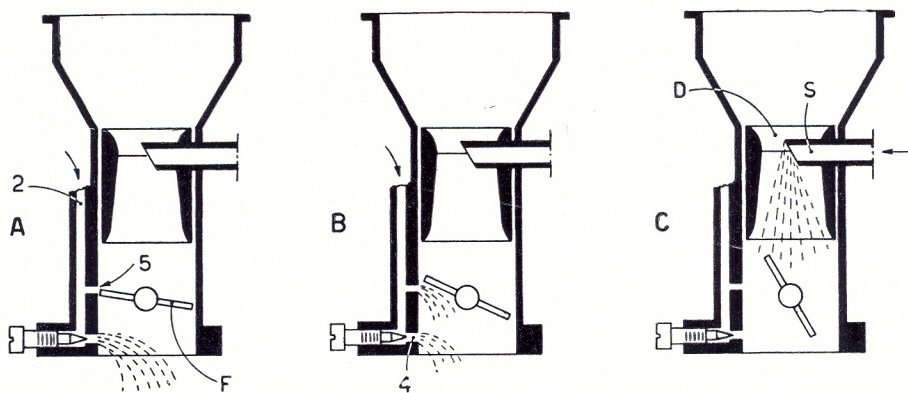

Fig. 1

D Venturi - F Throttle - S Spray nozzle - 2. Idle speed mixture duct - 4. Idle speed mixture orifice - 5. Transition orifice.

CONSTRUCTIONAL FEATURES OF CARBURETORS

BASIC CARBURETOR DEVICES

In this section the carburetor will be divided in its essential parts which will be discussed separately and in detail to give the servicemen who will be called upon to repair the carburetor a chance to evaluate in full the functional importance of each of its constituent parts.

Basically, the carburetor consists of:

- 1) Idle speed and progression circuit
- 2) Main fuel feed circuit
- 3) Starting device or starter.

It is important to point out that a normally adjusted carburetor represents a compromise solution which on the whole meets the requirements of the engine. When any of its factory-set adjustments are modified, its functionality will inevitably be upset to a degree seldom justified by the improvements sought.

For instance, sometimes it is possible to increase the top speed of a car by fitting a larger-diameter Venturi and a suitable main jet: in this case, however, it will be found that slow running operation is slightly worsened.

Before any such modification, one should first consider if the desired improvement justifies the consequent faulty performance. This example confirms the above outlined assertion that a well-adjusted carburetor is invariably the best possible compromise between pick-up performance, fuel consumption and vehicle speed.

When an engine idles, that is, the car is at a standstill and engine turns over at around 450-600 r.p.m., the vacuum promoted under these conditions in the Venturi area is too weak to draw out any mixture through the spray nozzle, but this is handled by a small independent carburetor whose task is to give the engine a mixture in the amount and strength required to ensure smooth engine operation at low rotational speeds, at the same time developing just the power needed to overcome the resistance of the moving parts.

As a matter of fact, the three basic elements into which carburetors were divided in a previous paragraph are actually three complete and independent carburetors sharing in common a constant-level bowl for their fuel supply.

This usually holds true even when — as will be outlined later — the idle speed circuit does not derive its fuel supply directly from the bowl but from a well.

It then follows that the **starting device** makes engine starts possible when climatic conditions would otherwise give rise to starting difficulties, the **idle speed circuit** permits no-load operation and the **main feed circuit** allows the attainment of all the performances that a car is expected to give under normal service conditions. Therefore, when the engine operates in the conditions illustrated in **A, Fig. 1, (no-load)**, only one of the three carburetors mentioned above is operative and yet is so self-sufficient that smooth operation is possible even without the contribution of the Venturis, main jet, emulsion tube, etc.

With engine under **no-load — Fig. 1** — a gear engaged and the accelerator depressed, the **transition orifice** comes into play and « progressively follows » the engine — **diagram B** — until spray nozzle **S** takes over — **diagram C**.

Each of the three small carburetors considered has a specific task within well-defined limits: if one retards or advances its function engine operation will be irregular. This is why the tuning of a carburetor consists in synchronizing the three components.

1) IDLE SPEED AND PROGRESSION CIRCUIT

Considering that obtain the desired smoothness of engine operation at idle speed and during progressive acceleration the supply of an air/fuel mixture of suitable strength is an essential condition, it follows that the carburetor must necessarily incorporate one calibrated jet — **idle speed jet** — to meter the fuel

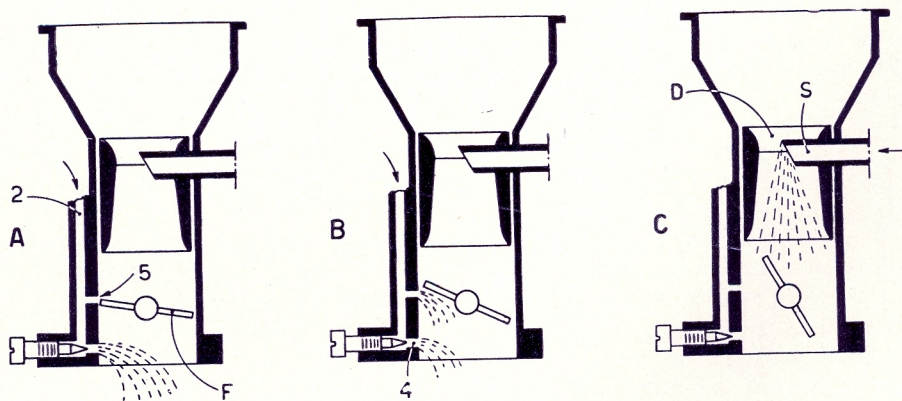

Fig. 1

D Venturi - F Throttle - S Spray nozzle - 2. Idle speed mixture duct - 4. Idle speed mixture orifice - 5. Transition orifice.

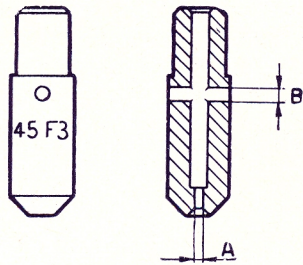

Fig. 2

and another calibrated jet — **idle speed air jet** — to meter the air: the mixture thus preformed is quantitatively adjusted by an **idle speed mixture set screw** and will then be ready to blend with the air drawn in by the engine across the throttle opening.

Such an idle speed air jet may consist of a true jet or, much more usually, of a calibrated orifice, and has the purpose of «correcting» the fuel flow in the idle speed circuit. When we speak of «varying the correction», we refer to an idle speed air orifice the diametric variation of which results in a change of fuel flow from the idle speed jet.

Two idle speed correction systems are adopted on WEBER carburetors:

- a) - correcting action obtained in the idle speed jet itself;
- b) - correcting action obtained in the carburetor body or by an independent air jet.

The calibrated diameter of these correction orifices must be considered as metering elements and, as such, must not be tampered with.

Figs. 2 and 3 show, respectively, an idle speed jet with incorporated «correction» (system a above) and an idle speed jet with independent «correction» (system b above). There is a further important element distinguishing the types of idle speed jets: for instance, the jet of DR type carburetors is stamped with the letter F meaning that the «correction» incorporated in the jet is in accordance with system a and, hence, the correction hole diameter (dimension B, Fig. 2) is rigorously calibrated.

On the other hand, when no identification letter is found on the idle speed jet, the correction is obtained in the carburetor body. In this case (dimension B, Fig. 3) the hole, or holes, drilled in the jet are simply fuel passages.

Two examples of correction system designations are:

- 1) 45 F3 — system a
- 2) 45 — system b.

In both cases, number 45 indicates the jet's calibrated diameter (in 1/100 of mm) while symbol F3 identifies the particular amount of correction which the jet

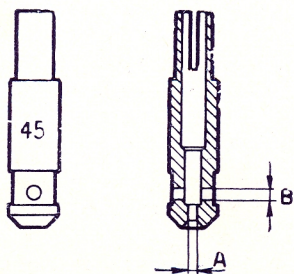

Fig. 3

in question incorporates. There are several types of correction design, each identified by its own symbol: a 45 F3 jet is corrected in a different way from a 45 F5 jet.

Symbols F3, F5 etc., represent units of measure and are only indicative values. Dimension A — Figs. 2 and 3 — both show the diameter of the jet.

Let us now consider the carburetor shown in Fig. 4 where the type a correction system is obtained directly on idle speed jet 7 by two calibrated orifices 6. Since the throttle is almost completely closed, the engine-promoted vacuum acts on idle speed orifice 14 whose adjustment is obtained by means of taper point screw 13.

Through duct 10 the vacuum reaches mixture passage holes 4 and then, via the jet body, correction orifices 6 which are open to the atmosphere through duct 2. The vacuum downstream of the throttle lifts the natural level of the fuel which, by overcoming head A is pre-emulsified with the correction air and flows down to the engine after passing through duct 10 and receiving a quantitative metering by mixture adjustment screw 13.

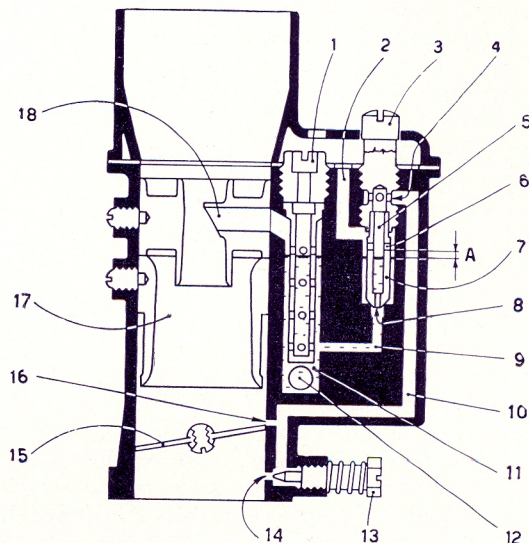

Fig. 4

1. Air corrector jet - 2. Idle speed air duct - 3. Idle speed jet holder - 4. Mixture passage holes - 5. Idle speed jet axial orifice - 6. Calibrated correcting orifices - 7. Idle speed jet - 8. Calibrated orifice - 9. Duct, idle speed jet-to-well - 10. Idle speed mixture duct - 11. Well - 12. Duct, main jet-to-well - 13. Idle speed mixture adjustment screw - 14. Idle speed mixture orifice - 15. Throttle - 16. Transition orifice - 17. Primary Venturi - 18. Spray nozzle.

Orifice 8 represents the calibrated part of the jet and is a very important element because it meters the amount of fuel that blends with the air metered by correction orifices 6.

In this design, from bowl 11 fuel reaches the idle speed jet through duct 9.

The idle speed circuit correction obtained in carburetor body (system b) is seen in Fig. 5 where an example of an IM series carburetor is shown.

In this case, only the indication of diameter calibration is stamped on idle speed jet 5. Correction is obtained here by a specially designed and calibrated bush called «idle speed air bush» and marked 2 in the illustration.

Clearly visible in **Fig. 5** are the following:

- A — Idle speed head
- 2 — Idle speed air bush
- 3 — Idle speed jet holder
- 5 — Idle speed jet
- 6 — Idle speed mixture transfer holes
- 7 — Idle speed jet metering orifice
- 8 — Duct, well-to-idle speed jet
- 9 — Idle speed mixture duct
- 11 — Duct, main jet-to-well
- 16 — Emulsion tube (*).

By overcoming head **A** the air drawn in through bush **2** lifts the fuel by the amount allowed by the calibration of orifice **7** under idle speed jet **5**.

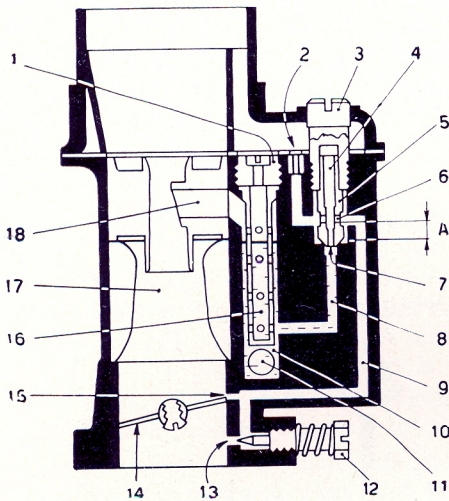

Fig. 5

- 1. Air corrector jet - 2. Idle speed air bush - 3. Idle speed jet holder - 4. Idle speed jet axial hole - 5. Idle speed jet - 6. Idle speed mixture transfer holes - 7. Metering orifice - 8. Duct, well-to-idle speed jet - 9. Idle speed mixture duct - 10. Well - 11. Duct, main jet-to-well - 12. Idle speed mixture set screw - 13. Idle speed orifice - 14. Throttle - 15. Transition orifice - 16. Emulsion tube - 17. Primary Venturi - 18. Spray nozzle.

Let us reconsider the vacuum that develops around idle speed orifice **13** when throttle **14** is almost totally closed: under these conditions the engine runs without load and supplies the bare power required to overcome the passive resistance of mechanical components. On account of the succession of intake stages, engine suction determines a pulsating air flow: the larger the number of cylinders the less pulsating will this suction be. It follows that in the purely theoretical case of an infinite number of cylinders, air would be aspirated steadily, without pulsations.

When the throttle is in the idle speed position, which is obtained by a set screw, the aspiration-promoted air flow finds its way across the gap around the throttle — **Fig. 6**.

It is this very gap that determines the degree of vacuum which, by acting on the idle speed orifice, draws out the air/fuel mixture required by the engine.

(*) In common usage the emulsion tube is often called «emulsion well»: this an error because by «well» is intended the cavity where the emulsion tube is housed.

The idle speed orifice in the carburetor barrel is always located down-stream of the throttle while the transition orifice is always upstream.

With engine r.p.m. steady, the greater the amount of throttle closing the stronger the vacuum on idle speed orifice in the inlet duct, due account being taken of the fact that beyond a given throttle «choking» limit the engine cannot keep going.

Idle speed adjustment: suppose we pose ourselves the problem of determining the **sensitivity** of idle speed adjustment in an engine running under no-load and with idle speed mixture set screw perfectly adjusted: we must then turn the set screw and find out by how many degrees it must be rotated, either way, before engine r.p.m. drops as a result of the **leanness** or **richness** of the mixture.

Let us assume that after moving set screw **12** (Fig. 5) a quarter turn the engine r.p.m. drops and that the same thing happens when the screw is turned the same amount the other way; in this case the screw has a **sensitivity** of a 1/2 turn (1/4 + 1/4). If it is desired to increase this sensitivity, just widen the idle speed orifice, say, from 110 to 120.

Under these conditions, in fact, by acting on screw **12** the **annular** gap around its taper point is wider than the original one. We thus notice that the sensitivity of screw **12** is no longer of half a turn (180°) but less (for instance, 130°).

We shall now consider the condition in which an idle speed circuit may be defined as properly adjusted. For normal automotive engines the idle speed rate is generally in the 450-600 r.p.m. range.

Assuming we have an engine whose rotational speed is within acceptable limits, the following considerations may be made:

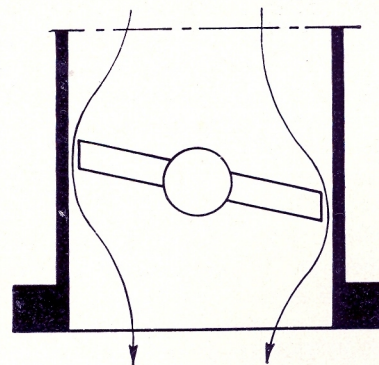

Fig. 6

- 1) By turning in the mixture set screw, the engine r.p.m. increases: in this case, the mixture is **rich** and the screw must be closed until the point of maximum angular speed is reached, without modifying the throttle opening.
- 2) By turning out the mixture set screw, the engine r.p.m. increases: this time the mixture is **lean** and the action to be taken is exactly the opposite to 1), viz., the mixture must be strengthened to obtain the optimum ratio.
- 3) By turning either in or out the mixture set screw, the engine r.p.m. decreases: carburetion is now the best possible, i.e., the mixture set screw is in the right position to supply the desirable air/fuel mixture.

As a rule, once the optimum set screw position is found it is advisable to leave the screw just a bit open, that is, slightly on the **rich** side. In attempting to define what is exactly meant by a proper idle speed adjustment we may say that it is the setting which allows engine operation at the maximum r.p.m. rate with respect to a given throttle opening.

Transition or (progression) orifice.

As explained previously, the vacuum around the idle speed mixture orifice in the carburetor barrel — **Fig. 1** — is strongest when the engine is running under no-load but when the accelerator pedal is pressed this vacuum decreases: as a result, less mixture is supplied while more air is drawn in by the engine. The mixture becomes excessively weak and the progression of engine acceleration is faulty.

Hence, an additional supply of mixture must necessarily be contributed to compensate for this idle speed orifice deficiency and allow the engine to pick up speed. To this end, a hole called the « **transition orifice** » is drilled in the barrel, in line with the upper edge of the throttle, so that it will be uncovered as soon as the throttle is acted upon and will thus be in a condition to supply its mixture.

As a calibrated metering element, the transition orifice is incorporated in every carburetor; even 2 or 3 of these orifices may be present, however, depen-

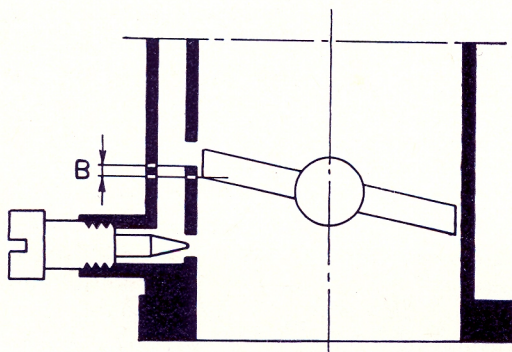

Fig. 7

ding on functional requirements. Their diameter is dependent upon engine characteristics and their location is always referred to the throttle in its fully-closed position. The transition orifice(s) is upstream of the throttle and dimension **B**, — **Fig. 7** —, represents the orifice **blanking head**, namely, the distance which the lower edge of throttle must travel before the orifice can supply any mixture.

This head and the diameter of the orifice are two factors of primary importance. While the diameter has great significance from the functional standpoint, dimension **B** determines the instant in which the transition orifice begins to supply the mixture.

In fact, as long as head **B** is not **completely overcome**, the vacuum on the transition orifice will not be strong enough to force out the mixture and the engine will be fed by the idle speed orifice alone.

Thus, if head **B** is changed, also the progression range of acceleration will vary; this is the reason why the transition orifice is always drilled in reference to the throttle.

It should be noted that with respect to the carburetor barrel longitudinal axis — **Fig. 8**, — the fully-closed throttle forms a given angle: this angle is marked on all throttles and is a determining factor which, if varied, will also change head **B**.

For instance, if an 87° throttle is fitted in place of an 85° throttle, head **B** is inevitably changed. It follows, evidently, that when a replacement is made the new throttle must necessarily have the same inclination (marked in degrees) as the one replaced. In case of a major overhaul requiring a polishing of the carburetor barrel, remember that also this operation may vary the head: if polishing increases the diameter of the barrel, evidently the fully-closed throttle would be located farther from the transition orifice than it was before. Let us now see what functional consequences arise from the erroneous position of head **B**. In **Fig. 9** the throttle is **always in the same idle speed position** but, according to the position of transition orifice, we have:

diagram A - correct location of orifice and head

diagram B - orifice moved upstream: positive head

diagram C - orifice moved downstream: negative head.

Correct location of orifice and head — Diagram A.

Idle speed operation and progressive acceleration are normal. When engine idles, the transition orifice is

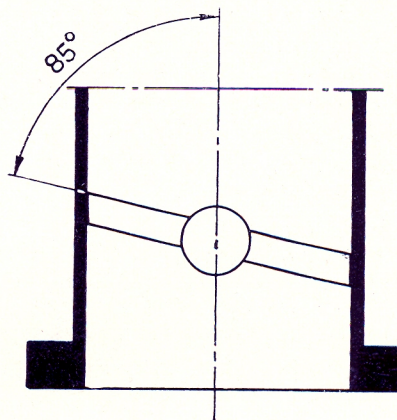

Fig. 8

excluded since is not yet uncovered but simply tangent to throttle.

Orifice moved upstream: positive head — Diagram B.

Idle speed operation is normal but in the progressive acceleration stage a **flat spot** develops and the engine may stop because of excessive mixture leanness.

In fact, being too high upstream, the transition orifice is acted upon by the vacuum a bit too late: consequently, the mixture leans out because the engine promotes a flow of air which is excessive in relation to the amount of fuel supplied by the idle speed orifice in the carburetor barrel.

Orifice below throttle: negative head — Diagram C.

Irregular running is generally due to a rich mixture. In fact, owing to the negative value of the head the transition orifice is under vacuum also at idle speed

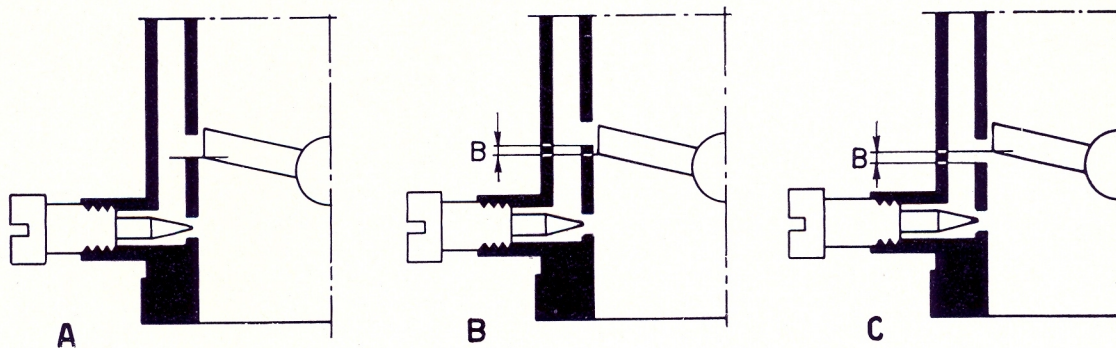

Fig. 9

and, therefore, delivers fuel which enriches the mixture.

Under these conditions, cases are met in which the engine runs at idling speed with completely tightened. idle adjustment screw, galloping engines, etc. Again, referring to **diagrams A and B, Fig. 9**, it may be said that in both cases idling is normal, but if the situation is examined more closely it will be seen that in **diagram B** the adjusting screw is more « open » than in **diagram A**, so that, when the engine is in the suction stroke, some of the air enters the mixture duct above the throttle and leans the pre-formed mixture.

In the discussion on **Fig. 9** we analyzed the engine operation to find out the irregularities. Let us now see how the defects may be remedied in practice. In the case of **diagram A of Fig. 9** everything is regular and no action need be taken.

For **diagram B**, on the other hand, the head must be corrected to the required value and this is obtained by machining a small chamfer in the throttle — **Fig. 10** — so that the excessive head is reduced. This operation must be performed in steps, by trial. The condition shown in **diagram C of Fig. 9** is corrected by drilling a small hole in the throttle on the side opposite the idle orifice — **Fig. 11**: some of the air drawn in by the engine may then flow through this hole and thus the throttle may remain more closed.

Enlarge the hole by small increments until the throttle blanks entirely the transition orifice thus providing the required head.

It is understood that the above remedies — i.e., chamfer and hole — are to be considered as actions taken to correct only **small carburetion troubles** arising from replacement of the throttle, cleaning of the barrel, etc.

So, for instance, in the case of **Fig. 11** it is of no

use trying to increase the head once the throttle has reached the closed position because of the hole drilled in it.

It now remains to be seen how a correct carburetion in the progression range may be checked.

Theoretically, once the idle speed is properly adjusted, the position of the mixture adjusting screw should remain unchanged throughout the progression range.

In practice, however, things may be different and the progression could be either so slightly on the rich or lean side that under a normal inspection, carburetion appears correct.

After adjusting the idle speed, turn the throttle opening setscrew so as to increase the engine RPM rate (e.g., from 500 to 800 RPM) but not up to the point where the nozzle starts operating. After this, check if at this speed (800 RPM) the mixture screw may still be left in the pre-established position.

For example: if by further backing the idle mixture adjustment screw at 800 RPM the engine speeds up, this means that the progression mixture is lean. On the other hand, if the engine speeds up when the screw is turned in the mixture is rich.

In the no-load operation it is advisable to adjust the mixture screw so as to render less marked the progression defect, even if idling smoothness must be partially sacrificed.

In the following figures some examples of solutions adopted for idle mixture duct drilling are given.

Fig. 4 shows a classic diagram where the idle speed jet is supplied with fuel by well **11** which, in turn, receives fuel from the bowl through the main jet and duct **12**.

This is the more common arrangement, but in some designs the idle jet receives fuel directly from the bowl.

An intermediate solution is illustrated in **Fig. 12**

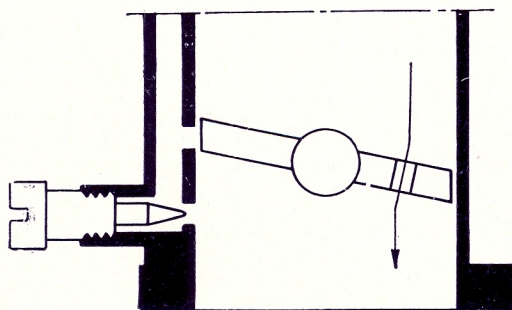

Fig. 10

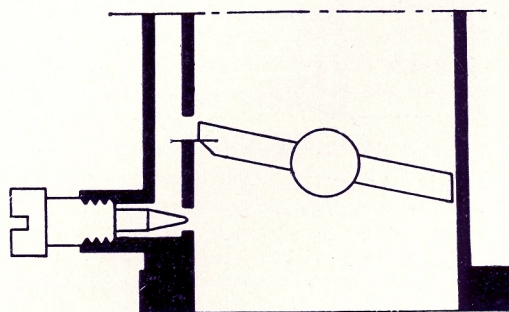

Fig. 11

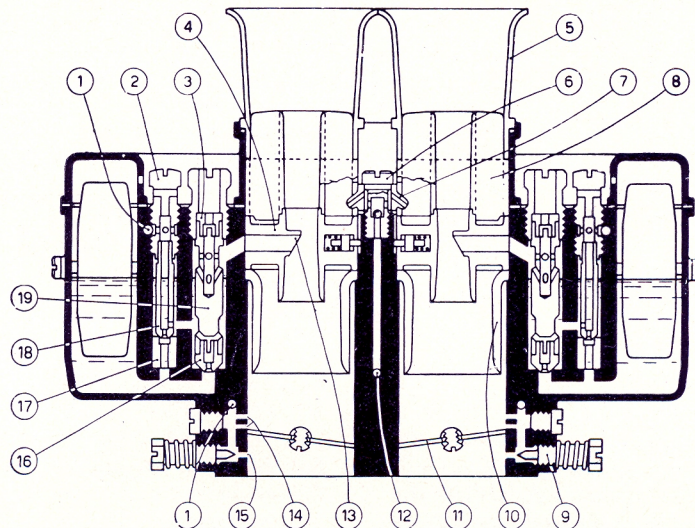

Fig. 12

1. Idle mixture ducts - 2. Idle speed jet holder - 3. Air corrector screws - 4. Secondary Venturis - 5. Additional air horns - 6. Ball delivery valves - 7. Pump jet bodies - 8. Venturi extensions - 9. Idle mixture adjustment screws - 10. Primary Venturis - 11. Throttles - 12. Pump delivery duct - 13. Nozzles - 14. Transition holes - 15. Idle mixture orifices - 16. Main jets - 17. Idle mixture jet bushes - 18. Idle mixture jets - 19. Emulsion tubes.

where the idle speed fuel is derived both from the bowl (back of main jet) and from the well. This last arrangement is common with the 40 IF-4C carburetors for Aston-Martin, Pegaso Z102, Ferrari 166-250-375 engines, etc.

As to the idle mixture circuit on Fig. 13 in which fuel is drawn from the well, it should be noted how the fuel delivery duct is generally on a level with the last row of air corrector holes in the emulsion tube.

The position of the duct is justified by the fact that when the engine runs at full speed duct 13 too is empty, but as soon as the accelerator is released the engine would tend to stop if the idle speed jet were not immediately supplied with fuel from the well.

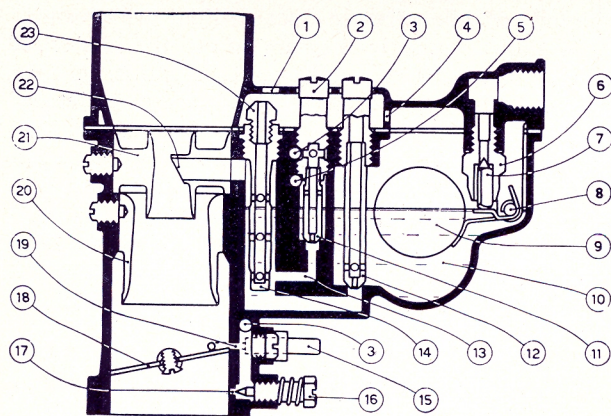

Fig. 13

1. Air inlet port - 2. Idle jet holder - 3. Idle mixture duct - 4. Bowl air orifice - 5. Idle air duct - 6. Needle valve - 7. Valve needle - 8. Float fulcrum pin - 9. Float - 10. Bowl - 11. Idle speed jet - 12. Main jet - 13. Duct, idle speed jet to well - 14. Emulsion tube - 15. Vacuum advance connection tube - 16. Idle mixture adjustment screw - 17. Idle speed orifice to throat - 18. Throttle - 19. Transition orifice - 20. Primary Venturi - 21. Auxiliary Venturi - 22. Nozzle - 23. Air corrector jet.

By deriving duct 13 at the height of the last row of the air corrector holes in the emulsion tube the above duct is more promptly filled with fuel resulting in improved acceleration progression when the engine is subjected to quick and successive accelerations.

2) MAIN FEED SYSTEM

This second section will deal in detail with the following items.

- a) main jet
- b) main jet holder
- c) emulsion tube
- d) air corrector jet
- e) Venturi (primary)
- f) Venturi (auxiliary) and nozzle
- g) constant-level system.

The first step is to investigate how mixture is formed in the well. For reference see Fig. 14 showing a section of downdraft carburetor type DR.

The fuel flows from the bowl, through duct 10, to well 11 where it reaches the same level as in the bowl.

Until no vacuum acts on nozzle 1 the fuel level in the well is as indicated by measure A.

As soon as the vacuum created by engine suction acts on nozzle 1, air enters through air corrector orifice 2, is metered by calibrated hole 3, flows through axial hole 5 of emulsion tube 4 and issues through calibrated holes 6. In its high-speed flow the air drags along fuel by overcoming the liquid head B and the emulsion thus formed reaches nozzle 1 where it mixes with the air stream flowing through the throat.

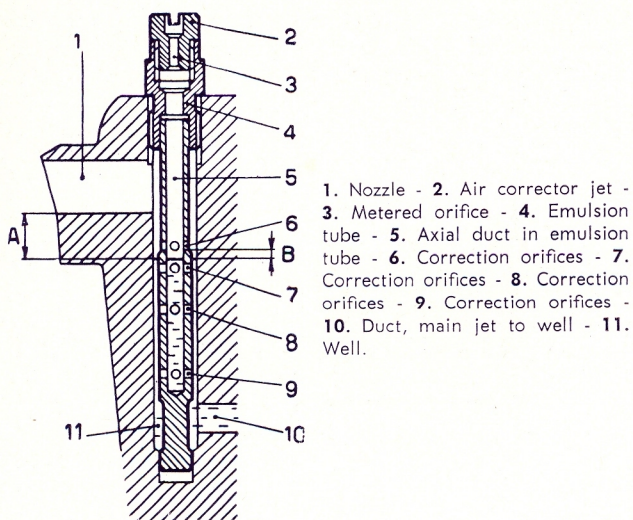

Fig. 14

As the engine speed increases, a larger amount of air flows through corrector orifice 2, and progressive uncovering of holes 7, 8, and 9 occurs until space 5 remains empty and the fuel level drops down to the height of the last row of emulsion holes.

When the engine is slowed down the decrease in vacuum causes a progressive rise of fuel in the well until at idling speed its level again reaches the height of fuel in the bowl.

In the following analysis of the elements forming the main feed system the importance of every item in regard to its specific function will become apparent.

a) Main jet

This jet the calibrated part that is most sensitive to possible tampering. Fig. 15 shows a standard jet housed in its holder; radial holes C are transfer orifices.

By observing the jet it is seen that its capacity depends on dimensions A and B.

It is apparent that, considering two jets, identical in diameter (dimension A), but differing in the length

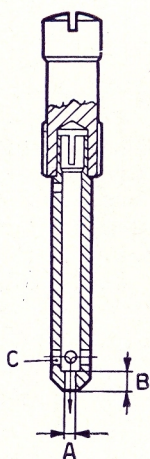

Fig. 15

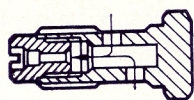

Fig. 16



Fig. 17

of the calibrated portion, the shorter jet in B will have a greater capacity.

In fact, in this case load losses will be lesser and a greater amount of fuel issues through the jet.

All jets used in Weber Carburetors are stamped with diameter dimension A (in hundredths of millimeter).

As regard actual operation, the diameter of the four transfer holes C will be such as to warrant, in any case, a capacity greater than rated. Fig. 16 and 17 illustrate two other types of main jets mounted in their holders.

The application of main jet 15 and of jet 14 is shown in Figs. 18 and 19 respectively. The jet in Fig. 15 is bayonet-coupled directly to the holder while that in Fig. 17 is held in place by the holder tip bayonet-coupled to holder body. The jet in Fig. 16, instead, is screwed tightly into the holder.

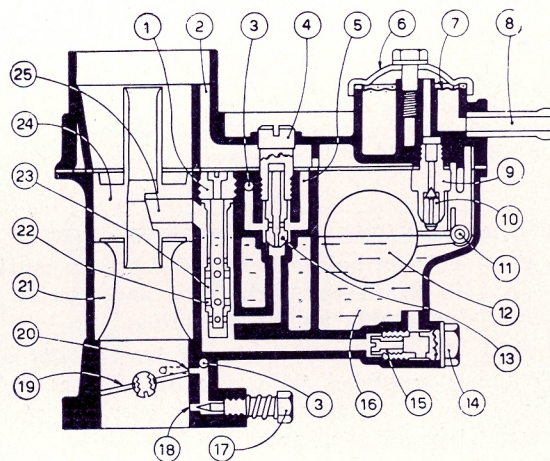

Fig. 18

1. Air corrector jet - 2. Air inlet duct - 3. Idle mixture duct - 4. Idle jet holder - 5. Idle air duct - 6. Filter cover - 7. Filter gauze - 8. Fuel inlet connection - 9. Needle valve - 10. Valve needle - 11. Float fulcrum pin - 12. Float - 13. Idle speed jet - 14. Main jet holder - 15. Main jet - 16. Fuel bowl - 17. Idle mixture adjustment screw - 18. Orifice, idle orifice to throat - 19. Throttle - 20. Transition orifice - 21. Primary Venturi - 22. Emulsion orifices - 23. Emulsion tube - 24. Auxiliary Venturi - 25. Spray nozzle.

The jets are accurately checked with very sensitive air flowmeters and the accuracy of machining allows perfect interchangeability. Should it be required to vary the capacity for functional reasons, the jet must be replaced by another having a different calibration.

Entry of fuel into the calibrated portion of the jet may take place either upwards — Figs. 15 and 17 — or downwards — Figs. 20 and 21.

These figures show how emulsion tube 4 carries jet 7 at one end and air corrector 3 at the other.

Two main jets are installed in dual throat carburetors: each jet supplies one of the throats with fuel drawn from the bowl.

A dual throat carburetor may, therefore, be defective due to improper functioning of only one of the jets and this will cause irregular running of the engine.

b) Main jet holder

Some of the principal Weber-manufactured main jet

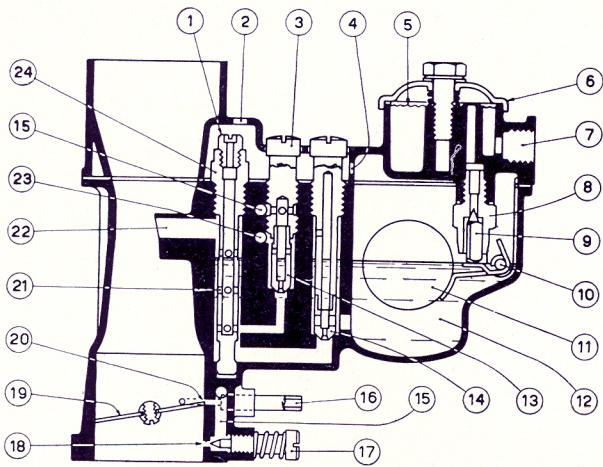

Fig. 19

1. Air corrector jet - 2. Air inlet port - 3. Idle jet holder - 4. Bowl air port - 5. Filter gauze - 6. Filter cover - 7. Fuel inlet connection - 8. Needle valve - 9. Valve needle - 10. Float fulcrum pin - 11. Float - 12. Fuel bowl - 13. Idle speed jet - 14. Main jet - 15. Idle mixture duct - 16. Vacuum advance connection - 17. Idle mixture adjusting screw - 18. Orifice, idle jet to duct - 19. Throttle - 20. Transition orifice - 21. Emulsion holes - 22. Nozzle - 23. Idle air duct - 24. Emulsion tube.

holders are illustrated in the following figures:

Fig. 15 — This jet holder is threaded on the outside to fit in the carburetor and carries an inner hole for jet mounting;

Fig. 16 — This holder is mounted horizontally and is provided with two transversal holes on offset axes for better entrance of the incoming fuel from the bowl.

Fig. 20 — Type of jet used on **OTS** carburetors. Compared with the others, it is particular in that it has two orifices for the admission of air to the corrector jet. Orifices 2 are not calibrated.

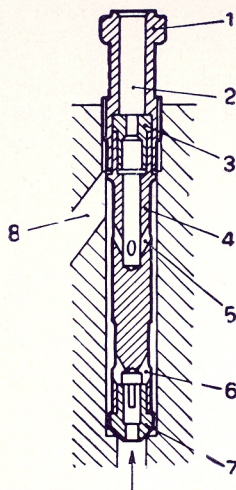

Fig. 20

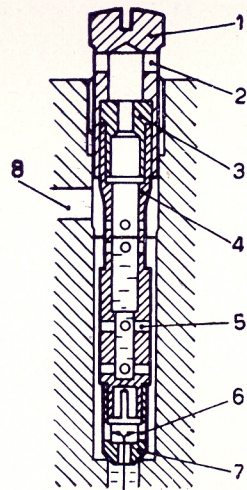

Fig. 21

1. Emulsion tube holder - 2. Air holes - 3. Air corrector jet - 4. Emulsion tube - 5. Air corrector holes - 6. Fuel holes - 7. Main jet - 8. Mixture duct to nozzle.

1. Emulsion tube holder - 2. Air axial hole - 3. Air corrector jet - 4. Emulsion tube - 5. Air corrector holes - 6. Fuel holes - 7. Main jet - 8. Mixture duct to nozzle.

Fig. 21 — Type of jet used on special carburetors. Orifice 2 permits the entrance of air to the corrector jet and, contrary to the jet in **Fig. 20**, is drilled axially.

c) Emulsion tube

Its task is to emulsify the air previously metered by the corrector with the fuel coming from the main jet.

Fig. 22 shows the same emulsion tube illustrated in **Fig. 13** which is designed for the **DR** type carburetor.

The dimension diagram illustrated in **Fig. 22** is practically the same for all types of carburetors and may be taken as a basis for our study.

Dimensions G - H - I: are the diameters of the air corrector holes and are those which determine the acceleration progression regularity. Particularly important is diameter **G** of the first row of holes since

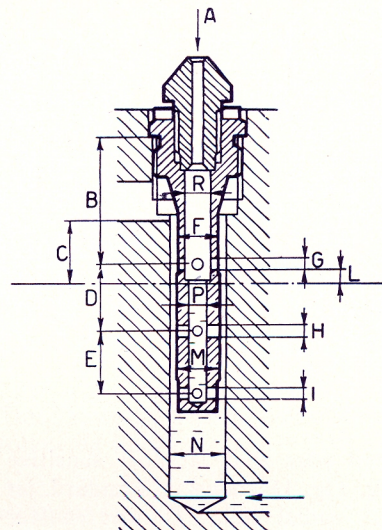

Fig. 22

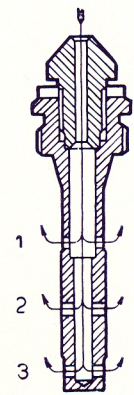

Fig. 23

it is the size of these holes, along with head **L**, that governs the beginning of delivery from the nozzle. If dimension **L** is less than specified the nozzle will start delivering fuel before time thus giving a rich mixture. Conversely, a lean mixture will result if **L** is in excess of the specified value.

It is therefore evident that head **L** has been so set as to be overcome only by a given vacuum at the nozzle. If the head is overcome before or after the specified vacuum at the nozzle is reached, acceleration irregularities will occur as described above. In fact, when at a given opening of the throttle both the idle jet and the transition orifice are not sufficiently responsive to the vacuum formed in the throat, the engine must be fed by the nozzle. But, for instance, if **L** is excessive, with the throttle opened as indicated above, the vacuum at the nozzle will still not be such as to cause fuel to issue from the nozzle and therefore a lean mixture will be had in the acceleration stage.

Dimensions M - N: diameter **M** in the true dimension of the emulsion tube. In fact, the same carburetor

body will adapt emulsion tubes with different diameters **M** though well diameter **N** remains the same. **Fig. 23** illustrates the air flow path in the emulsion tube during full-throttle running.

Figs. 24-25 and 26 illustrate some emulsion tubes for Weber carburetors.

It should be noted that the tubes shown in **Fig. 26** are not thread-mounted but are fitted free in the carburetor body: they are kept in place by the air corrector jet when it is screwed into place.

Furthermore, it is again pointed out that every emulsion tube is stamped with a symbol that identifies it from the others which, though having the same serial number, have different dimensions.

The chart of **Fig. 27** shows that among emulsion tube metered parts identified by letters **A-B-C-D-E-F**, both diameter **A** and the diameter of the air corrector holes may vary. The result is that the emulsion tube identified as **TS 534a** takes the suffix **F.6 - F.10 - F.15** depending on the diameter of the air corrector holes.

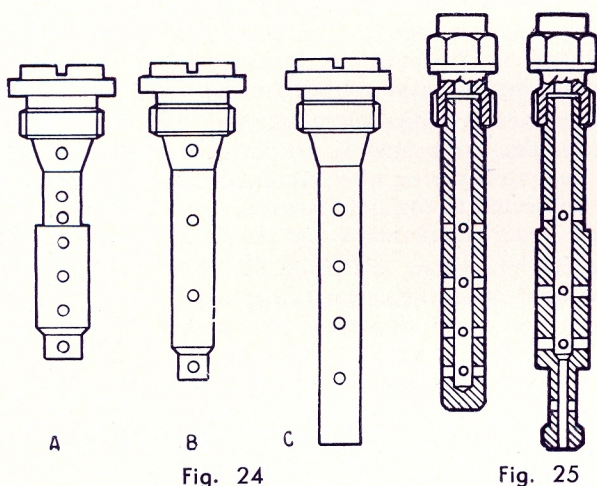

Fig. 24

Fig. 25

An emulsion tube may be fully identified only if the Serial Number is followed by the size of the corrector holes, the latter also being the corrector system symbol.

d) Air corrector jet

This jet meters the amount of air that enters the emulsion tube and mixes with the fuel. It is a metered part having the same importance as the main jet with the exception that functions are reversed: when the corrector jet diameter is increased the mixture is weaker.

In **Figs. 14, 21, 22 and 28** different types of air corrector jets are shown.

As for the main jets, so also the corrector jets have a working capacity which varies with metered diameter and the length of the calibrated portion. The number stamped on the jets indicates the diameter expressed in hundredths of a millimeter.

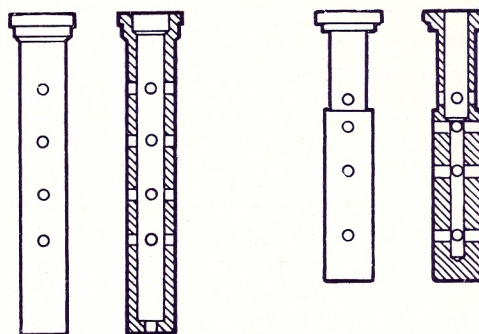

Fig. 26

e) Primary Venturi

the vacuum created by the cylinders draws air from outside. This air, after passing through the carburetor air cleaner, reaches the carburetor air horn and then the throat. Due to the restriction provided by the Venturi the air speed is increased and a vacuum is formed which draws fuel from the nozzle. The

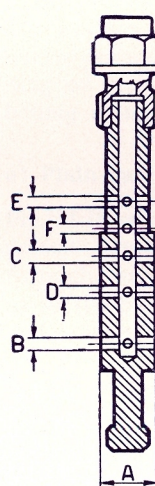

Fig. 27

Tube Type	A	B	C	D	E	F
F 4	5 ²⁵	125	100	—	100	—
F 5	6 ²⁵	125	100	125	100	—
F 6	5 ²⁵	125	100	—	100	125
F 8	5 ²⁵	125	100	125	100	125
F 9	6 ²⁵	125	100	125	100	125
F 10	4	125	95	125	95	—
F 11	4	—	—	125	95	—
F 15	6	200	—	—	—	—

greater the restriction of the Venturi the greater the vacuum at the nozzle which, therefore, will draw a greater amount of fuel from the well.

However, no variation in the Venturi constriction is possible in any Venturi since this variation calls for replacement of the main jet; because in a properly designed carburetor these two parts are correlated.

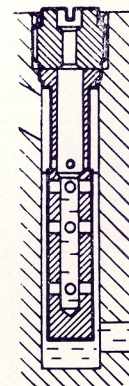

Fig. 28

Operating conditions may be as follows:

- 1°) by reducing the Venturi — and consequently the main jet — power and consumption will drop but pick up will remain good;
- 2°) by increasing the Venturi alone consumption will drop but pick up will be worsened;
- 3°) by increasing both Venturi and main jet, power and consumption increase. Pick up is less brilliant but the drawback is easily overcome by installing an accelerating pump.

The possible increase in power is, of course, dependent on engine characteristics.

Stamped on every Venturi is a number corresponding to its diameter, expressed in millimeters.

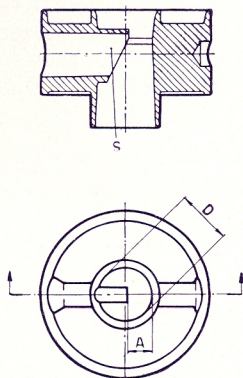

Fig. 29

f) Auxiliary Venturi

The auxiliary Venturi — Fig. 29 — carries calibrated nozzle S which communicates with the well. Engine suction will create a vacuum at the nozzle

varying with the throttle opening, engine RPM and the diameter of the primary Venturi. The nozzle section has a considerable bearing on fuel consumption. The diameter of the nozzle is stamped on every auxiliary Venturi in mm., e.g. 3 - 3.5 - 4 - 4.5, etc.

The auxiliary Venturi rarely undergoes damage liable to impair its functional efficiency. However, care must be taken during assembly to prevent deformations that might possibly alter dimensions D and A. In fact, if these dimensions are reduced the vacuum at the nozzle increase and consumption would increase. Also a flattening of the nozzle would affect consumption.

g) Constant-level system

The fuel level in a bowl may reach different heights depending on the adjustment of the tang supporting needle valve 10 — Fig. 18.

Once a given setting has been established and a given type of carburetor has been decided, the fuel level in the bowl becomes one of the factors determining the adjustment. In fact, it is the level in the bowl that establishes the head of fuel.

To prevent changes in level, and therefore in the head, the carburetor is so designed that the level is kept steady even when the liquid mass in the bowl is subjected to dynamic stresses as occurs on curves and under acceleration and deceleration conditions.

Special provisions are made for both the float and the bowl when the carburetor may be subject to operating on steep slopes, as in the case of the agricultural tractor carburetor in Fig. 30.

In any case the carburetor installation must be such that the bowl is oriented in the direction of forward travel.

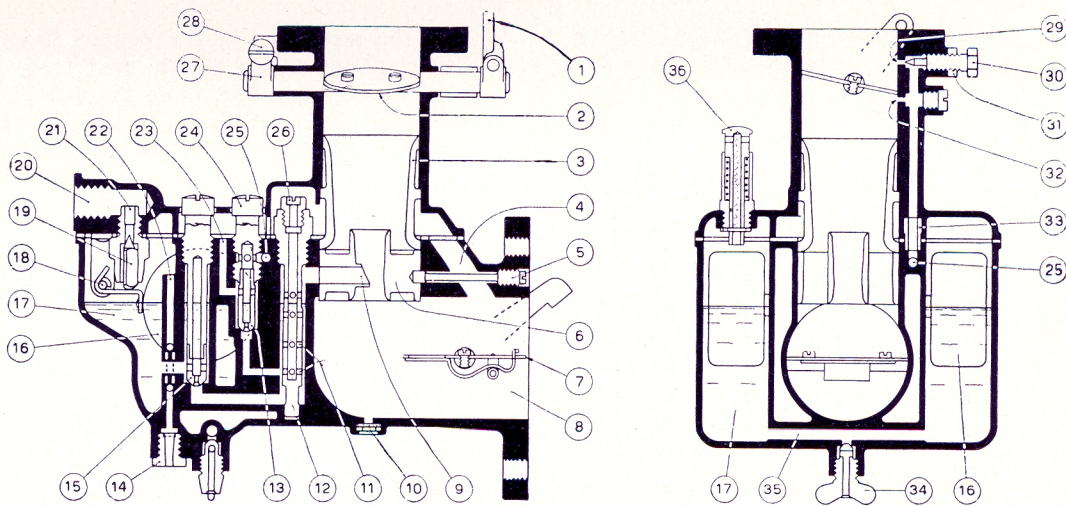

Fig. 30

1. Primary throttle control lever - 2. Primary throttle - 3. Primary Venturi - 4. Air corrector intake duct - 5. Auxiliary Venturi fixing screw - 6. Auxiliary Venturi - 7. Starting throttle - 8. Air horn - 9. Main nozzle - 10. Air horn drain plug - 11. Emulsion holes - 12. Emulsion tube - 13. Idle speed jet - 14. Bowl air duct plug - 15. Main jet - 16. Float - 17. Bowl - 18. Float fulcrum pin - 19. Valve needle - 20. Fuel inlet connection - 21. Needle valve - 22. Bowl air duct - 23. Idle speed air duct - 24. Idle speed jet holder - 25. Idle mixture duct - 26. Air corrector jet - 27. Sector for primary throttle - 28. Idle speed adjustment screw - 29. Orifice, idle jet to duct - 30. Idle mixture adjustment screw - 31. Locknut - 32. Transition orifice - 33. Idle mixture duct bush - 34. Bowl drain cock - 35. Bowl drain duct - 36. Primer rod.

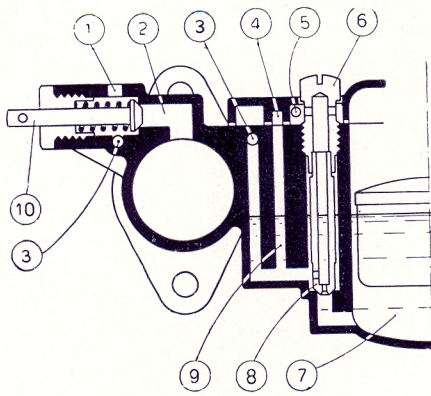

Fig. 31

1. Emulsion air orifice - 2. Starting mixture duct - 3. Starting mixture duct - 4. Emulsion air slot - 5. Emulsion air orifice - 6. Starting jet holder - 7. Bowl - 8. Starting jet - 9. Reserve starting well - 10. Starting valve.

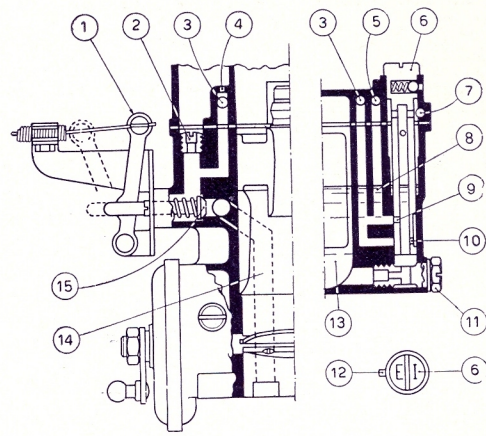

Fig. 32

1. Starting valve control lever - 2. Starting air jet - 3. Mixture duct - 4. Emulsion air orifice - 5. Emulsion air orifice - 6. Starting mixture control - 7. Air control orifice - 8. Reserve starting well - 9. Climatic control orifice (summer) - 10. Climatic control orifice (winter) - 11. Starting jet - 12. Starting mixture adjustment screw index - 13. Bowl - 14. Starting mixture duct - 15. Starting valve.

3) STARTING DEVICE (STARTER)

The starting systems are based on two principles:

- 1) Auxiliary carburetor system
- 2) Choke system

They may be actuated manually, i.e., directly by the driver, or operate automatically under the action of a thermo-sensitive control (bi-metallic lamina or thermostatic capsule).

1. Auxiliary carburetor systems

They consist of a small carburetor incorporated in the main carburetor and may be of three types:

- a) plain valve
- b) Economy-Super-Aspiration (E.S.A.) device
- c) progressive operation

Type a) includes the starting valve devices which, by a manual control, may be thrown in or out without intermediate settings.

Type b) covers the devices which, besides the above fixed position, permit intermediate settings either

for economic running or over-feeding.

The devices which supply the engine with a mixture whose composition and amount are variable, depending on the extent of insertion of the device itself, belong to type c).

a) Plain valve starting device

Fig. 31 illustrates the OTS type of carburetor starting device. The fuel, coming directly from bowl 7, flows through metered jet 8 and reaches the same height as in the bowl. With the throttle in the idle position and taper valve 10 being open, the vacuum promoted by the starter-cranked engine acts on duct 3 and draws the mixture already blended with air coming through orifice 5. Still under the action of vacuum, air enters through orifice 1 and blends with the mixture pre-formed in duct 3.

Fig. 32 shows the diagram of the DCLD dual-throat carburetor starting device. A two-position climatic control is fitted in this case (E = Summer; I = Winter) so as to have available two grades of mixture

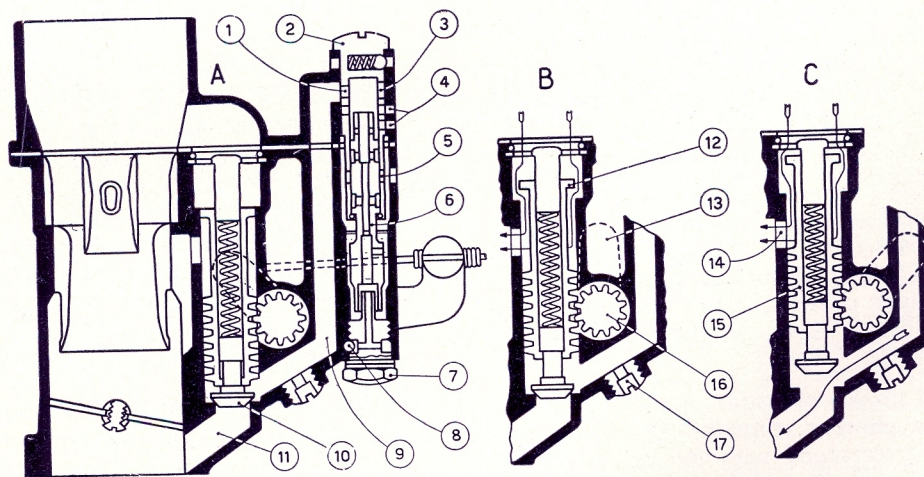

Fig. 33

1. Mixture orifice (summer) - 2. E.S.A. control - 3. Mixture orifice (winter) - 4. Emulsion air holes - 5. Supplementary air hole - 6. Sliding tube - 7. E.S.A. jet - 8. Fuel duct - 9. Mixture duct - 10. E.S.A. valve - 11. E.S.A. mixture duct - 12. Distributor - 13. E.S.A. control lever - 14. Supplementary air duct - 15. Rack - 16. Gear - 17. E.S.A. air jet.

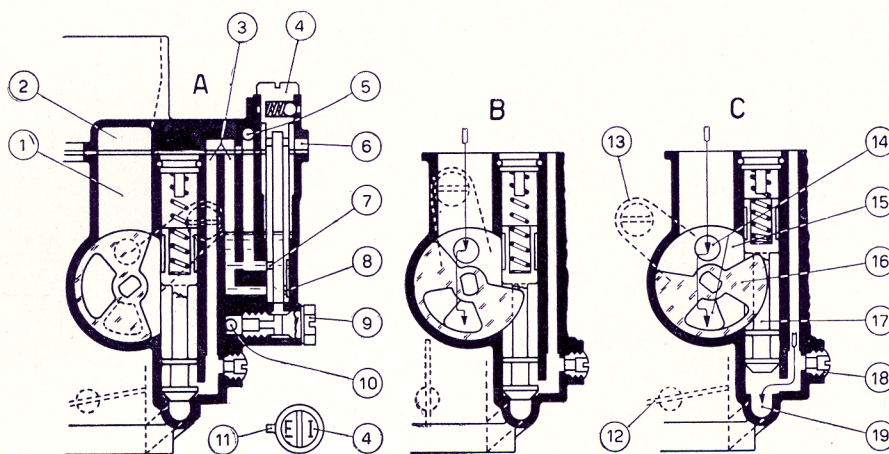

Fig. 34

1. Supplementary air duct - 2. Supplementary air intake - 3. Mixture ducts - 4. E.S.A. control - 5. Emulsion air orifice - 6. Emulsion air orifice - 7. Mixture orifice (summer) - 8. Mixture orifice (winter) - 9. E.S.A. jet - 10. Fuel duct - 11. E.S.A. control index - 12. Throttle - 13. E.S.A. control lever - 14. Supplementary air communication slots - 15. Fixed diaphragm - 16. Movable diaphragm - 17. E.S.A. valve - 18. E.S.A. air jet - 19. Mixture duct.

depending on climatic conditions. If control 6 is turned with letter **I** in line with index 12 the mixture will be richer. Conversely, mixture will be leaner when letter **E** is lined up with index 12.

By considering the position of Fig. 32 — summer — it may be seen how the fuel passes from bowl 13 to metered jet 11. As valve 15 is opened — the throttles being in the idle speed position — the engine-promoted vacuum draws, through duct 3, the mixture formed by fuel arriving from starting jet 11 and air through orifices 5 and 7. Since the control is in the **E** (summer) position, the mixture flows through calibrated hole 9. Were the control to be oriented on **I** (winter) the mixture would pass through hole 10 whose diameter is larger than that of hole 9.

b) Economy-Super-Aspiration (E.S.A.)

The E.S.A. is mounted in two versions (carburetors of the **DR** and **DRN** series) illustrated respectively in Figs. 33 and 34. These versions are similar, with the exception that in the **DR** type carburetor — Fig. 33 — the supplementary air inlet is provided through a rack-controlled valve while, in the **DRN** type carburetor, — Fig. 34 — the air inlet is provided through the rotation of a movable diaphragm on a fixed diaphragm.

From the operation diagram in Fig. 33 it is apparent that fuel arrives from the bowl through duct 8, passes metered E.S.A. jet 7, orifice 1 (summer) or 3 (winter) of climatic control 2, valve 9, E.S.A. valve 10, duct 11 and finally flows to the throat downstream of the throttle.

For a correct and proper operation of the E.S.A. the letter stamped on climatic control 2 (**E** = summer; **I** = winter) must correspond with the reference index on the carburetor cover. In this way the mixture, formed by fuel coming from jet 7 and air drawn in through orifices 4, is metered by calibrated orifice 1 (summer) or 3 (winter). These orifices are drilled in

control 2 in such a way that the device supplies the most suitable mixture ratio.

E.S.A. operation under the several possible conditions is as follows:

Normal operation - Diagram A of Fig. 33

The E.S.A. taper valve 10 and distributor 12 are closed: the device is inoperative and carburetion normal.

Economic operation - Diagram B of Fig. 33

By partially pulling the knob on the panel, without overcoming the stiffening point determined by the spring dog, the bowden-controlled lever 13 causes the rotation of gear 16 which lifts rack 15 and, hence, distributor 12 from its seat. Taper valve 10 is kept shut by a spring housed in the rack.

This causes a supplementary passage of air coming from the carburetor horn through duct 14 ending in the carburetor throat, downstream of the primary Venturi.

By-passing the primary and the auxiliary Venturis the air does not promote the suction of fuel from the nozzle and consequently the mixture is weakened thus permitting a reduced fuel consumption.

Starting or overfeeding operation - Diagram C of Fig. 33

By pulling the knob on the panel fully over, gear 16 rotates a further angle and completely lifts rack 15 which, in turn, raises taper valve 10 from its seat. Under these conditions and with throttle in idle position the vacuum promoted by the starter-cranked engine causes the fuel to be first mixed with air entering through orifices 4. The mixture thus formed flows in duct 9, reaches taper valve 10 and is finally emulsified with the air drawn in through the hole metered by screw 17 and is conveyed to the carburetor throat downstream of the throttle via duct 11. With the engine started the engine-promoted vacuum on sliding tube 6 increases and tube 6

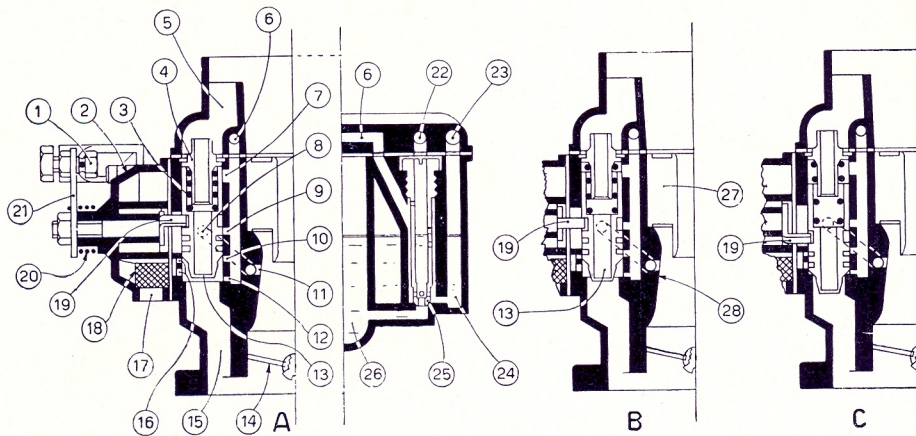

Fig. 35

1. Bowden screw - 2. Cover with bowden sheath support - 3. Spring - 4. Spring retainer and guide - 5. Air inlet - 6. Mixture duct - 7. Leaning air orifice - 8. Transition duct - 9. Transition orifice - 10. Starting mixture orifice - 11. Transition orifice - 12. Starting mixture orifice - 13. Starting valve - 14. Throttle - 15. Starting mixture duct - 16. Starting device air orifices - 17. Air intake slot - 18. Filter gauze - 19. Rocker - 20. Lever return spring - 21. Starting device control lever - 22. Starting jet emulsion air orifice - 23. Reserve well emulsion air orifice - 24. Reserve starting well - 25. Starting jet - 26. Bowl - 27. Auxiliary Venturi - 28. Primary Venturi.

risers and uncovers supplementary inlet port 5 through which emulsifying air is admitted with the consequent leaning out of the mixture drawn in through the E.S.A. This ensures a correct mixture even during the period in which the starting device operates. In this same starting position, **but with wide-open throttle**, the E.S.A. may also serve as **overfeeder** because, by permitting the entrance of an additional amount of mixture and air drawn in respectively through ducts 14 and 11 it boosts engine power by supplying a richer mixture.

How to use the E.S.A.

The rules to follow in order to derive the best advantages offered by the E.S.A. are briefly outlined below:

— **NORMAL OPERATION - Diagram A of Fig. 33 - Knob at rest against panel: normal carburetion.**

— **ECONOMIC OPERATION - Diagram B of Fig. 33 -**

Knob in intermediate position: as set by the spring-loaded dog: to be used with engine well warmed up, on level roads, also with partial and variable throttle openings. In this position the device may serve also as an altitude corrector on mountain journeys, above 2000 meters, since it corrects enrichment of the mixture which otherwise would remain lean on account of air rarefaction.

— **STARTING - Diagram C of Fig. 33 - Knob pulled fully over:** when used for starting purposes, the device must be excluded as soon as the engine has reached a sufficient temperature to ensure smooth and regular running.

— **OVERFEEDING - Diagram C of Fig. 33 - Knob pulled full over as for starting: position to be resorted to only when the maximum power is**

required of the engine, i.e., **only with wide-open throttle and at high engine speeds; not to be used when travelling with partial or variable openings of throttle.**

The E.S.A. shown in Fig. 34 calls for similar operation conditions.

c) Progressiv action starting devices

The progressive-action starting device is controlled by the panel knob and must be progressively shut off by the driver as the engine warms up. The device must be fully excluded when the engine has reached the rated operation temperature.

The starting device — Fig. 35 — consists of valve 13 actuated by the end of rocker 19 connected through a suitable spindle to control lever 21. By pulling the control fully over, the action of lever 21 and rocker 19 lifts valve 13 from its seat and the valve remains completely open.

Under these conditions valve 13 closes air orifice 7 and mixture orifice 9 while it uncovers both mixture orifices 10 and 12 which, through duct 6, communicate with starting jet 25. The valve also uncovers air orifices 16 in communication with the atmosphere via filter gauze 18 and slots 17. Orifice 9 may communicate with the carburetor throat (with valve 13 partially open) through the central flute of the valve, through duct 8 and orifice 11 drilled in the restricted section of Venturi 28.

With the throttle in the idle position, the vacuum promoted by the starter-cranked engine causes the fuel in the starting jet housing, the starting jet 25 and reserve well 24, to be emulsified with the air coming from orifices 22 and 23.

Through duct 6, orifices 10 and 12, and duct 15 the mixture reaches the outlet, downstream of the throttle and mixes with the air entering from orifices 16, thus permitting a prompt start.

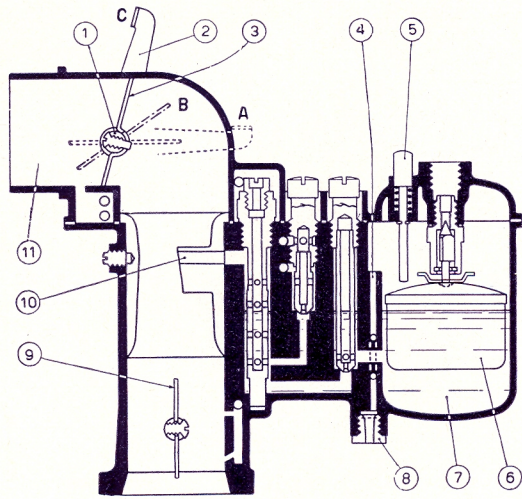

Fig. 36

1. Starting throttle shaft - 2. Starting throttle control lever - 3. Starting throttle (choke) - 4. Overflow duct - 5. Primer rod - 6. Float - 7. Bowl - 8. Plug for overflow duct - 9. Main throttle - 10. Nozzle - 11. Air horn.

As the device is being shut off, valve 13 progressively uncovers orifice 7 so allowing an additional amount of air to enter through valve guide 4, giving a leaner mixture; at the same time, the valve blanks orifices 10 and 12 and air orifices 16 thus reducing the amount of incoming mixture.

In this way the less the device is inserted the leaner will the air-fuel mixture be and the quantity delivered will be reduced.

Mixture orifice 9, duct 8, and orifice 11, drilled in Venturi 28 have the task of permitting a regular progression of acceleration even with a cold engine. By opening throttle 14 to speed up the engine, the vacuum acting on duct 15 is reduced. This would cause a reduction in the amount of fuel delivered through duct 15, with consequent irregular running of the engine, but, through orifice 11, duct 8 and orifice 9 (from which air is drawn when the throttle is closed) some mixture is aspirated by the vacuum formed in the restriction of the Venturi consequent on the opening of the throttle, and

this compensates for the reduction in delivery through duct 15.

When the starting device is excluded, valve 13 covers also orifice 9 and prevents the entrance of mixture.

2) Strangler throttle (choke) type starting devices

The starting device incorporated in carburetors of the 26 DRT type — Fig. 36 — consists of choke 3, housed in air horn 11, and of primer 5 placed on the carburetor cover.

The butterfly is idle and eccentrically mounted on shaft 1 to which it is linked by a return spring.

To start the engine from cold, the float in the bowl is lowered by depressing rod 5 of the primer; this causes a rise in fuel level in bowl 7 up to the height of overflow duct 4. Lever 2, keyed on shaft 1 is brought to position « C » and choke 3 blanks air horn 11. Main throttle 9 is set in the wide-open position.

The engine-promoted vacuum reaches noticeable values due to the choking caused by butterfly 3 and a rich mixture is forced out of nozzle 10 with a consequent prompt starting of the engine.

As the engine is started, due to the suction, vacuum choke 3 rotates to position « B » (against the return spring) and a regular and smooth engine operation is obtained thanks to the rich mixture it receives. When the engine has reached a sufficient temperature to run smoothly and steadily, choke 3 is fully opened by moving lever 2 to position « A »; throttle 9 is set in the idle speed position.

The starting device of the 28TR type carburetors — Fig. 37 — consists of primer 3, housed in upper body at the height of the float and choke 9 installed in air horn 6. The choke is provided with a slot 5 blanked by a movable diaphragm 11 which is controlled by spring 10.

To start the engine from cold, the fuel level in bowl 7 is caused to rise by depressing rod 3 of the primer which, in turn, pushes down float 4. Lever 8 fixed to the shaft carrying throttle 9 is displaced in position « C » so that choke 9 blanks air horn 6. Main throttle 1 is set in a given position by means of the controls with which the vehicle is fitted.

1. Main throttle - 2. Nozzle - 3. Primer rod - 4. Float - 5. Starting throttle slots - 6. Air horn - 7. Bowl - 8. Starting throttle control lever - 9. Starting throttle (choke) - 10. Diaphragm spring - 11. Starting throttle diaphragm - 12. Air horn drain - 13. Bowl air duct plug - 14. Bowl air duct.

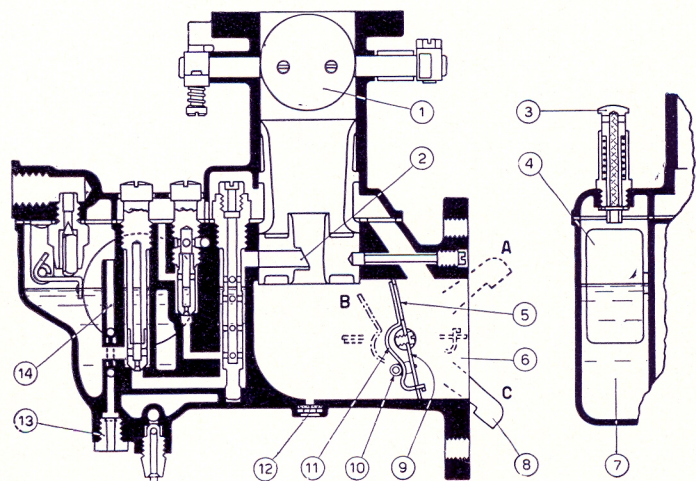

Fig. 37

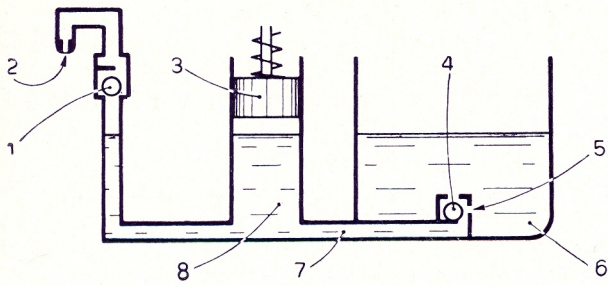

Fig. 38

1. Delivery valve - 2. Pump jet - 3. Pump plunger - 4. Inlet valve - 5. Drain hole - 6. Bowl - 7. Suction duct - 8. Pump barrel.

The engine-promoted vacuum reaches noticeable values due to the choking caused by butterfly 9 and a rich mixture is forced out of nozzle 2 with a consequent prompt starting of the engine. Once the engine is started, under the action of the vacuum diaphragm 11 takes position «B», overcoming the action of spring 10 and opens slot 5: this gives a sufficiently rich mixture to ensure regular and smooth engine operation. When the engine has reached the rated temperature, choke 9 is fully opened by moving lever 8 to position «A».

ACCELERATING PUMP

An accelerating pump is usually fitted on those carburetors which, on account of their characteristics, are adjusted to give high power and, in consequence, are provided with large diameter Venturis.

The accelerating pump injects into the carburetor barrel a given amount of fuel in a given time: the calibration of these two factors is the essential feature of this device.

By observing diagram Fig. 38 it is seen that through duct 7 fuel reaches pump barrel 8 in which plunger 3 works. Inlet valve 4, housed in bowl 6 admits fuel to the pump while delivery valve 1 checks it.

By depressing the accelerator, plunger 3 is rapidly pushed down, causing closure of the inlet valve and fuel is forced to issue through metered jet 2. A part of the fuel, however, returns to the bowl through drain hole 5. By releasing the accelerator pedal the vacuum caused when the plunger in the pump barrel rises, closes valve 1 so preventing the entry of air through pump jet 2. In this way pump cylinder 8 is re-filled, fuel being drawn into the barrel through valve 4 and drain hole 5.

Different amounts and duration of delivery are obtained by varying respectively the diameters of the pump jet and the drain hole.

In fact, by increasing the pump jet diameter a **greater** amount of fuel is injected, while by increasing the drain hole diameter a **shorter** injection will be obtained as the amount of fuel that will discharge through this hole instead of issuing through the jet will be greater.

It should be noted that variation in the metered elements of an accelerating pump brings about a variation in the pressure exerted by the plunger, and, theoretically, this would involve a number of elements which, to avoid complicating the discussion, are not mentioned here.

To determine the metering of both the pump jet and drain jet the first step is to establish the diameter of the pump jet according to the amount of fuel to be injected, then establish the diameter of the drain jet for the injection time desired.

A defective accelerating pump may bring about the following troubles:

- **clogged pump jet:** poor pick up; crackling due to lean mixture, etc.
- **stuck or clogged delivery valve:** incomplete filling of the pump barrel due to air infiltrations; poor pick up, crackling and impossibility of obtaining quick and successive accelerations.
- **clogged or stuck inlet valve:** on carburetors with a large drain orifice the trouble is little felt since the pump barrel may be filled rapidly via the drain orifice. Where the drain orifice is small, acceleration would be possible only at intervals because the pump would take more time to fill through the drain orifice.

1. Pump drain jet - 2. Pump control outer lever - 3. Pump jet - 4. Needle delivery valve - 5. Plunger return spring - 6. Main jet - 7. Emulsion tube - 8. Air corrector jet - 9. Dynamic air intake connection - 10. Idle speed jet - 11. Idle air jet - 12. Needle valve - 13. Valve needle - 14. Float fulcrum screw - 15. Float - 16. Bowl - 17. Pump inlet valve - 18. Idle mixture duct - 19. Idle duct and jet communication bushes - 20. Auxiliary Venturi extension - 21. Pump suction duct - 22. Pump plunger - 23. Nozzle - 24. Auxiliary Venturi - 25. Plunger stroke reduction spacer - 26. Primary Venturi - 27. Pump drain duct - 28. Throttle - 29. Transition orifice - 30. Orifice, idle jet to duct - 31. Pump drain duct - 32. Idle mixture adjustment screw - 33. Pump control rod - 34. Pump delivery duct.

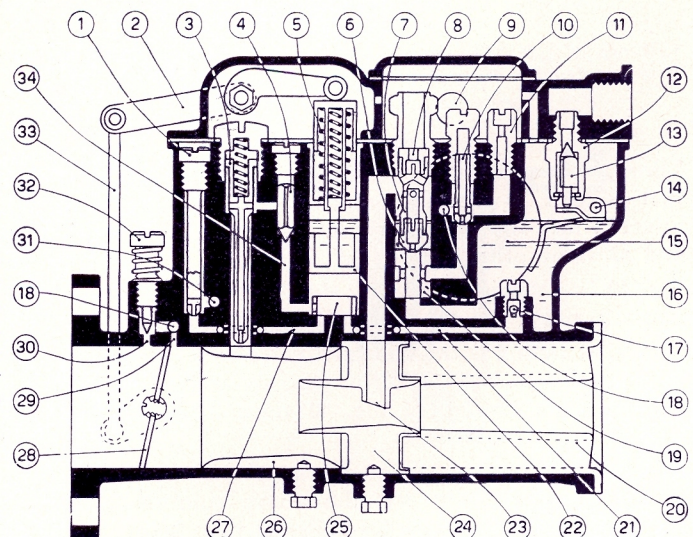

Fig. 39

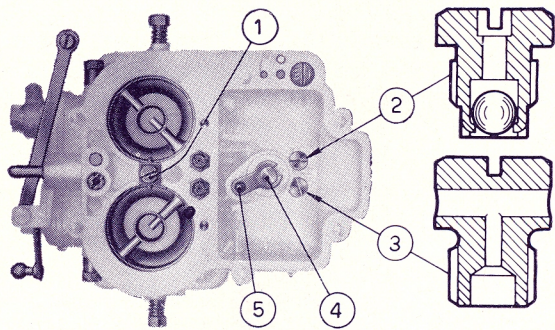

Fig. 40

1. Pump jet - 2. Inlet valve - 3. Drain jet - 4. Pump plunger - 5. Pump control rod.

— **clogged drain jet:** fast pick up due to the greater amount of fuel injected by the pump over a longer period.

Fig. 39 shows the section of a dual barrel horizontal carburetor where the accelerating pump consists of a metal plunger 22 controlled by throttle shaft via a linkage and spring system. When the throttles close, the system frees a suitable sliding stem which, under the action of spring 5, lifts plunger 22: fuel is thus sucked into the pump barrel from bowl 16 through valve 17 and duct 21. As the throttles are opened, the linkage system lowers the sliding stem against the action of spring 5 and depresses plunger 22 whose movement is governed by the pump spring housed in the stem itself.

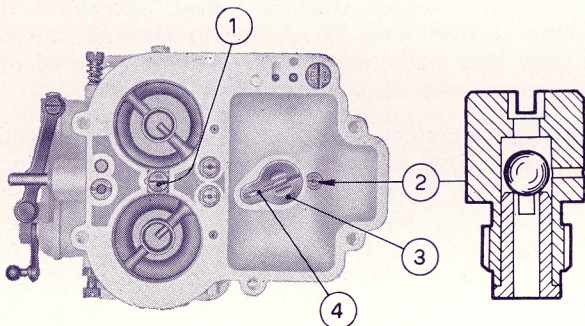

Fig. 41

1. Pump jet - 2. Inlet valve with drain hole - 3. Pump spring retaining plate - 4. Pump control rod.

Through duct 34 and via needle delivery valve 4, fuel is sent to metered pump jets 3 whence it is injected into the main carburetor barrels. **Fig. 40, 41 and 42** show other details.

Fig. 40 is an inner view of a dual-barrel body where items 2 and 3 are the inlet valve and the drain jet. In **Fig. 41** item 2 is the ball inlet valve which, through a metered side hole performs also as drain jet. This simplifies the design of **Fig. 40** since a single part performs two functions.

When conditions allow, such as in the case of a large diameter drain jet, the above solution may still be simplified. In fact, in **Fig. 42** item 2 consists

of a simple threaded plug on one side of which is drilled the metered drain orifice. During pump suction, filling of the barrel is ensured by the drain orifice through which, during injection, the excess fuel is also permitted to flow back to the bowl.

Another solution adopted in the single throat, down-draft carburetors of the **DRNP** series is shown in **Fig. 43**. In these carburetors the acceleration pump consists of a metal plunger 5 actuated by pump control rod 4 via lever 10 with roller which is fixed to the throttle shaft.

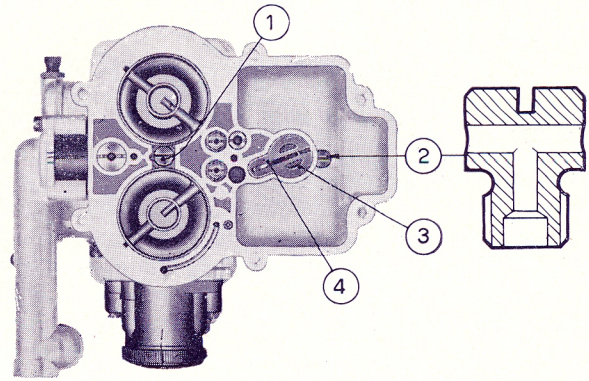

Fig. 42

1. Pump jet - 2. Pump inlet-drain jet - 3. Pump spring retaining plate - 4. Pump rod.

When closing the throttle, lever 10 lifts plunger 5 by means of rod 4. Fuel is then sucked from the bowl into the pump barrel through inlet valve 8 and duct 9. When the throttle is opened, rod 4 is released and plunger 5 is pushed down by spring 7. Through ducts 9 and 11 and valve 1 the fuel reaches metered jet 2 which sprays it into carburetor barrel. If it is desired to reduce the amount of fuel delivered by the accelerating pump, the carburetor in question may be equipped with a larger calibrated drain jet 3.

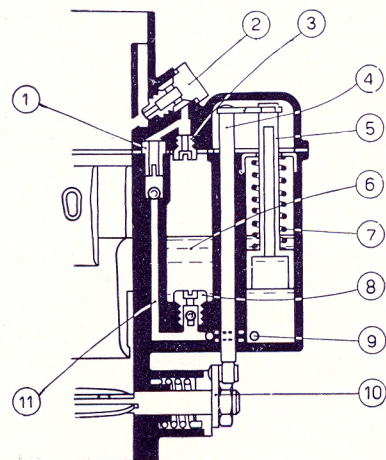

Fig. 43

1. Pump delivery valve - 2. Pump jet - 3. Pump drain jet - 4. Pump control rod - 5. Pump plunger - 6. Fuel bowl - 7. Pump spring - 8. Pump inlet valve - 9. Pump inlet-and-delivery duct - 10. Pump control lever - 11. Pump delivery duct.

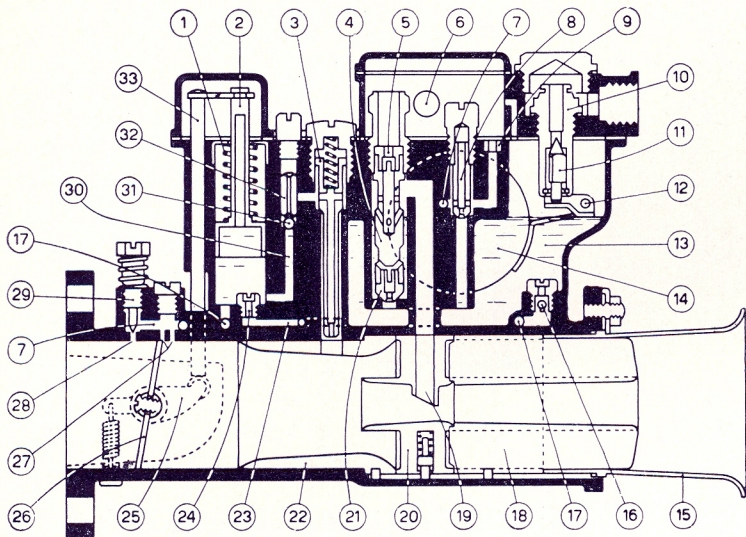

Fig. 44

Dual-barrel, horizontal carburetors — Fig. 44 — are fitted with drain jet 24 housed in the pump barrel itself. In some designs drain jet 6 is derived from the delivery duct, as shown in Fig. 45 illustrating a single-barrel, horizontal carburetor.

DUAL-BARREL CARBURETORS

In the first section of this discussion it was explained how the transition orifice, the well and the main jet enter into play progressively as the engine is accelerated from idle speed.

To simplify the explanation let us begin with the dual-barrel carburetor whose two throttles open simultaneously. Carburetor DCF illustrated in Fig. 46 is of this type and is fit for sport cars with large piston displacement engines.

On account of its special characteristics this carburetor has no starting device. The contemporaneous opening of the two throttles is obtained by two toothed sectors, one of which is adjustable.

Two ducts branch from bowl 15 and reach main jets 18, one for each barrel.

1. Pump spring - 2. Pump plunger - 3. Pump jet
4. Emulsion tube - 5. Air corrector jet - 6. Dynamic air intake connection - 7. Idle mixture duct - 8. Idle jet - 9. Idle air bush - 10. Needle valve - 11. Valve needle - 12. Float fulcrum screw - 13. Bowl - 14. Float - 15. Additional air horn - 16. Pump inlet valve - 17. Pump suction duct - 18. Auxiliary Venturi extension - 19. Nozzle - 20. Auxiliary Venturi - 21. Main jet - 22. Primary Venturi - 23. Pump drain duct - 24. Pump drain jet - 25. Pump control lever - 26. Throttle - 27. Transition orifices - 28. Idle orifice to duct - 29. Idle mixture adjustment screw - 30. Pump delivery duct - 31. Ball delivery valve - 32. Ball hold-down - 33. Pump rod.

Wells are never in communication with each other, since they may be considered as separate devices with autonomous functions.

Since the throttles open at the same time, both nozzles start supplying fuel simultaneously. Idle speed adjustment is obtained by the two screws 37, while there are two transition orifices 38 for each barrel. On account of the contemporaneous action, the parts intended for the two barrels must evidently have the same calibration, as against other dual-barrel carburetors where the differential opening of the throttles permits adoption of different calibration values for the primary and secondary throats.

The accelerating pump has nothing peculiar excepting pump jets 30 which have two delivery orifices; as no drain jet is provided in this carburetor, to reduce the amount of fuel delivered by the pump plunger 19 must have a hole.

The DCF, synchronized opening type carburetors are usually fitted on the manifolds whose duct may feed one single cylinder or a group of cylinders independently of the others. The importance of accurate location of the transition orifices in the two barrels is, therefore, apparent to prevent any unbalanced feed of the single cylinders or groups thereof.

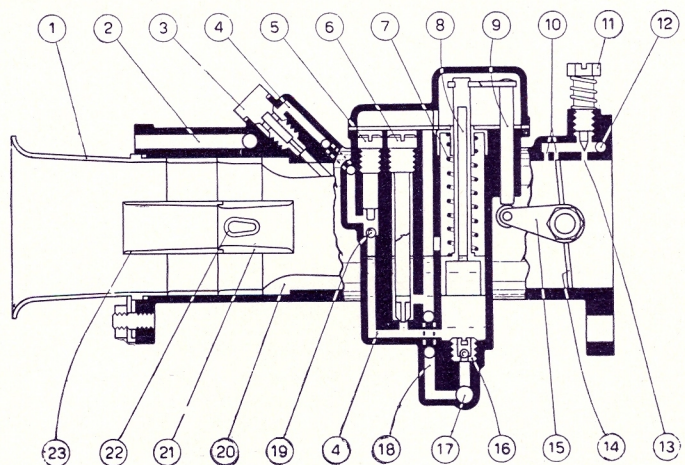

Fig. 45

1. Additional air horn - 2. Air inlet for bowl and emulsion tube - 3. Pump jet - 4. Pump delivery duct - 5. Pump ball delivery valve retaining screw - 6. Pump drain jet - 7. Pump spring - 8. Pump plunger - 9. Pump control rod - 10. Transition orifices - 11. Idle mixture adjustment screw - 12. Idle mixture duct - 13. Orifice, idle jet to duct - 14. Throttle - 15. Pump control lever - 16. Pump inlet valve - 17. Bowl communication duct - 18. Pump drain duct - 19. Pump delivery valve - 20. Primary Venturi - 21. Auxiliary Venturi - 22. Main nozzle - 23. Auxiliary Venturi extension.

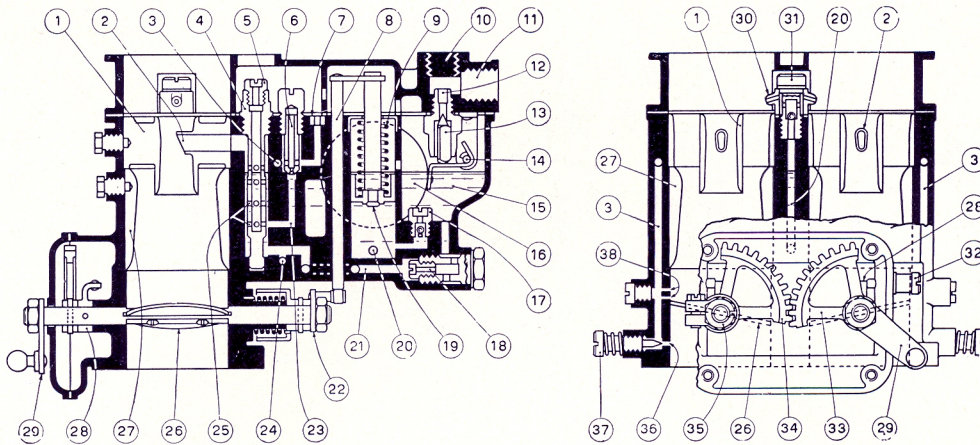

Fig. 46

1. Auxiliary Venturi - 2. Nozzles - 3. Idle mixture ducts - 4. Emulsion tubes - 5. Air corrector jets - 6. Idle mixture jets - 7. Idle air bushes - 8. Pump rod - 9. Pump spring - 10. Boss for fuel inlet connection (vertical) - 11. Fuel inlet connection (horizontal) - 12. Needle valve - 13. Valve fulcrum pin - 14. Bowl - 15. Float - 16. Pump inlet valve - 17. Pump plunger - 18. Main jets - 19. Pump delivery duct - 20. Main jet-to-well ducts - 21. Pump control lever - 22. Idle jets-to-wells ducts - 23. Full power jets-to-well ducts - 24. Emulsion orifices - 25. Throttles - 26. Primary Venturis - 27. Stop sectors - 28. Throttle control main lever - 29. Pump jets body - 30. Ball delivery valve - 31. Idle speed adjustment screw - 32. Stationary toothed sector - 33. Adjustable toothed sector - 34. Adjustment bush - 35. Idle jet-to-duct orifices - 36. Idle mixture adjustment screws - 37. Transition orifices - 38.

Let us now see the diagram — Fig. 47 — of a DCLD type dual-barrel carburetor with differential opening of the two throttles.

The mechanism for differential opening of the two throttles consists of toothed sector 48, idle on primary throttle shaft 30 having slot 47 into which slides lug 43 of stop sector 44 fixed to shaft 30. Secondary throttle shaft 33 carries toothed sector 49. By actuating throttle control lever 29, lug 43 first slides into slot 47 of sector 48; throttle 26, on shaft 30, rotates through a corresponding angle while secondary throttle 32 remains closed. Subsequently, lug 43 drives sector 48 which, through sector 49, causes shaft 33 to rotate until both throttles are fully open.

The mechanism indicating the opening of the secondary throat consists of pushrod 42 with spring 41 housed in the toothed sector casing cover, and cam 46 having a suitable outline and fixed on primary shaft 30. By actuating the lever controlling secondary throttle 29 when this is opened, the accelerator pedal movement is somewhat stiffened. This stiffening, due to the action of cam 46 contacting pushrod 42, warns the driver that the secondary throttle has started opening.

After overcoming this point, and up to the opening of both throttles, the operation of the accelerator pedal becomes smooth again.

The two-dosage accelerating pump is incorporated to

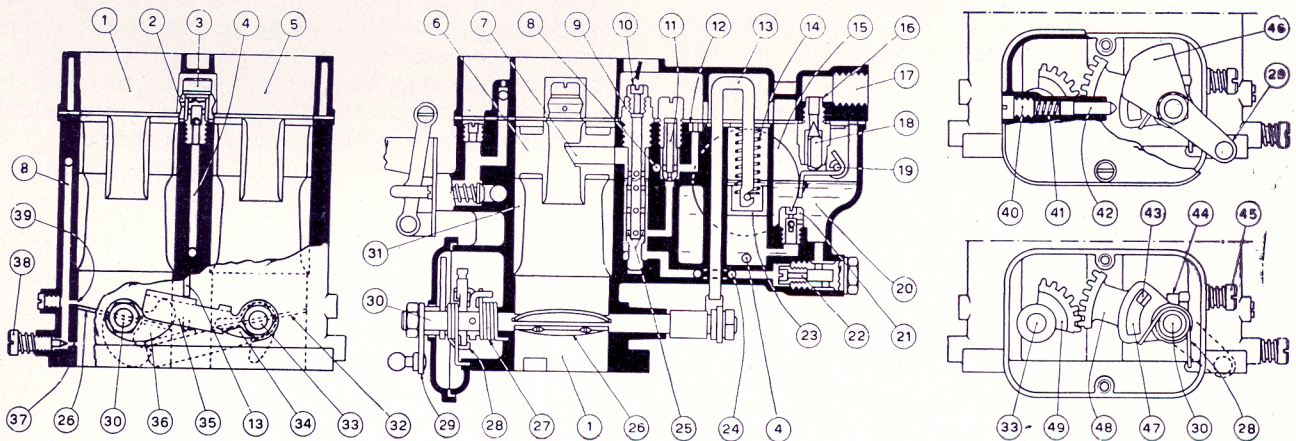

Fig. 47

1. Primary throat - 2. Pump jet - 3. Pump delivery valve - 4. Pump delivery duct - 5. Secondary throat - 6. Auxiliary Venturis - 7. Nozzles - 8. Idle mixture duct - 9. Emulsion tubes - 10. Air corrector jets - 11. Idle speed jet - 12. Idle air bush - 13. Pump rod - 14. Pump spring - 15. Float - 16. Needle valve - 17. Fuel inlet connection - 18. Valve needle - 19. Float fulcrum pin - 20. Bowl - 21. Pump inlet valve with drain orifice - 22. Main jets - 23. Pump plunger - 24. Jets-to-wells ducts - 25. Emulsion orifices - 26. Primary throttle - 27. Primary throttle return spring - 28. Secondary throttle return spring - 29. Throttles control main lever - 30. Primary shaft - 31. Primary throttles - 32. Secondary throttle - 33. Secondary shaft - 34. Pump control secondary lever - 35. Pump control neutral lever - 36. Pump control primary lever - 37. Idle jet-to-duct orifice - 38. Idle mixture adjustment screw - 39. Transition orifice - 40. Pushrod screw - 41. Pushrod spring - 42. Pushrod indicating the opening of secondary throat - 43. Lug - 44. Stop sector - 45. Idle speed adjustment screw - 46. Cam indicating the opening of secondary throat - 47. Slot in primary sector - 48. Primary toothed sector - 49. Secondary toothed sector.

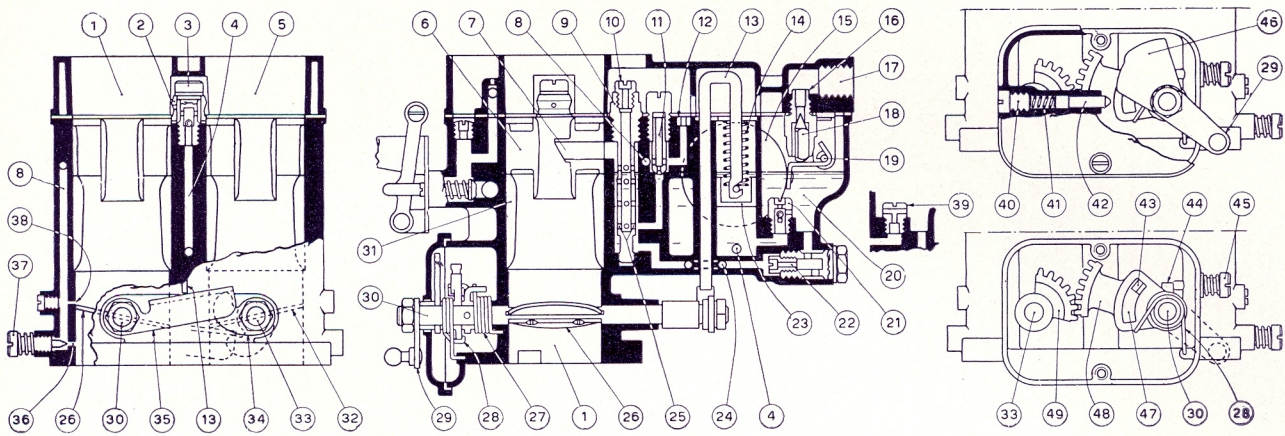

Fig. 48

1. Primary throat - 2. Pump jet - 3. Pump delivery valve - 4. Pump delivery duct - 5. Secondary throat - 6. Auxiliary Venturis - 7. Nozzles
 8. Idle mixture duct - 9. Emulsion tubes - 10. Air corrector jets - 11. Idle speed jet - 12. Idle air bush - 13. Pump rod - 14. Pump spring - 15. Float - 16. Needle valve - 17. Fuel inlet connection - 18. Valve needle - 19. Float fulcrum pin - 20. Bowl - 21. Pump inlet valve with drain orifice - 22. Main jets - 23. Pump plunger - 24. Jets-to-wells duct - 25. Emulsion orifices - 26. Primary throttle - 27. Primary throttle return spring - 28. Secondary throttle return spring - 29. Throttles control main lever - 30. Primary shaft - 31. Primary Venturis - 32. Secondary throttle - 33. Secondary shaft - 34. Pump control lever - 35. Pump control neutral lever - 36. Idle orifice to duct - 37. Idle mixture adjustment screw - 38. Transition orifice - 39. Pump inlet outlet screw - 40. Pushrod screw - 41. Pushrod spring - 42. Pushrod indicating the opening of secondary throat - 43. Lug - 44. Stop sector - 45. Idle speed adjustment screw - 46. Cam indicating the opening of secondary throat - 47. Slot in primary sector - 48. Primary toothed sector - 49. Secondary toothed sector.

provide a smooth acceleration as each of the two throttles opens.

This pump consists of a metal plunger 23 actuated by rod 13 through lever 35 neutral on secondary throttle shaft 33, lever 34 keyed to secondary throttle shaft and lever 36 fixed to primary shaft 30. As the throttles close, lever 36 lifts plunger 23 by means of lever 35 and rod 13, so that fuel is sucked from bowl 20 into the pump barrel through ball valve 21.

When the throttles are opened, shaft 30 rotates first with lever 36; lever 35 lowers until it contacts lever 34 of shaft 33 which has remained in the closed position. Under the action of spring 14, rod 13 and plunger 23 travel a given stroke and a metered amount of fuel is injected into primary barrel 1 through duct 4, valve 3 and pump metered jet 2. Subsequently, also shaft 33 rotates with lever 34; lever 35 lowers until it contacts lever 36 which is depressed: the

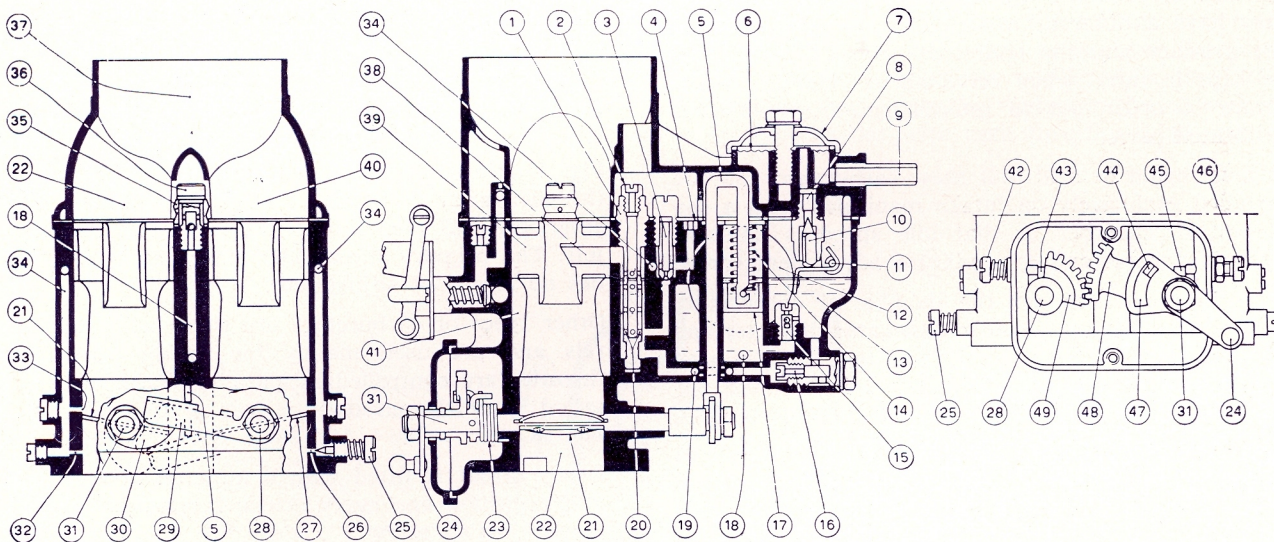

Fig. 49

1. Emulsion tubes - 2. Air corrector jets - 3. Idle jets - 4. Idle airbushes - 5. Pump control rod - 6. Filter gauze - 7. Filter cover - 8. Needle valve - 9. Fuel inlet connection - 10. Valve needle - 11. Float fulcrum pin - 12. Float - 13. Bowl - 14. Pump spring - 15. Inlet valve with drain orifice - 16. Main jets - 17. Pumpplunger - 18. Pump delivery duct - 19. Main jets-to-wells ducts - 20. Emulsion orifices - 21. Primary throttle - 22. Primary throat - 23. Primary throat return spring - 24. Throttles control lever - 25. Idle mixture adjustment screw - 26. Idle orifice to secondary throat - 27. Secondary throttle - 28. Secondary shaft - 29. Pump control neutral lever - 30. Pump control lever - 31. Primary shaft - 32. Idle orifice to primary throat - 33. Transition orifices - 34. Idle mixture duct - 35. Pump jet - 36. Pump delivery valve - 37. Air horn - 38. Nozzles - 38. Auxiliary Venturis - 40. Secondary throat - 41. Primary Venturis - 42. Secondary throat idle speed adjusting screw - 43. Secondary shaft stop sector - 44. Sector lug - 45. Primary shaft stop sector - 46. Primary throat idle speed adjustment screw - 47. Primary sector slot - 48. Primary toothed sector - 49. Secondary toothed sector.

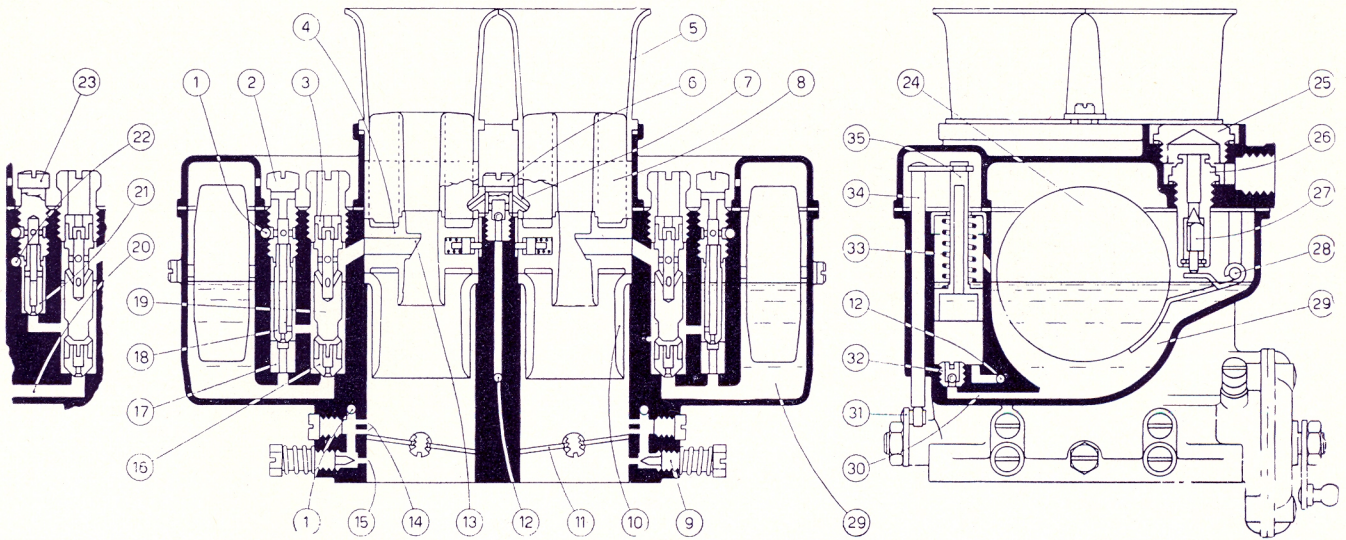

Fig. 50

1. Idle mixture ducts - 2. Idle jet holders - 3. Air corrector jets 4. Auxiliary Venturis - 5. Additional air horns - 6. Ball delivery valve - 7. Pump jet bodies - 8. Auxiliary Venturi extensions - 9. Idle mixture adjustment screws - 10. Primary Venturis - 11. Throttles - 12. Pump delivery duct - 13. Nozzles - 14. Transition orifices - 15. Idle orifices to duct - 16. Main jets - 17. Idle mixture bushes (two-stage system) - 18. Idle jets (two-stage system) - 19. Emulsion tubes - 20. Duct to bowl - 21. Idle speed jets - 22. Idle air ducts - 23. Idle jet holders - 24. Float - 25. Needle valve inspection plug - 26. Needle valve - 27. Valve needle - 28. Float fulcrum screws - 29. Bowl - 30. Pump inlet duct - 31. Pump control lever - 32. Pump inlet valve - 33. Pump spring - 34. Pump control rod - 35. Piston plunger.

plunger travels further and, therefore, the pump delivers a given amount of fuel also during the opening of the secondary throttle.

To reduce the amount of fuel delivered by the accelerating pump, inlet valve 21 may be furnished with a lateral calibrated hole which discharges the excess fuel into the bowl.

Contrary to the dual-barrel, simultaneous throttle opening carburetors, the carburetors described here may have a different metering of the elements for the primary and the secondary throat. This should be kept in mind when servicing or cleaning carburetors in order not to interchange or modify the calibrated parts.

It must again be said that these carburetors may be installed exclusively on intake manifolds with a single intake chamber so that idle speed is adjusted by only one jet and one mixture adjustment screw.

Next in the series are the dual-barrel carburetors that, though having barrels of the same diameter and differently calibrated parts for the two throats, have an accelerating pump which injects fuel in the primary throat when the secondary throttle is opened.

The pump — Fig. 48 — consists of a metal plunger 23 actuated by rod 13 through lever 35 (neutral on primary shaft 30) and lever 34 keyed to secondary shaft 33. As the throttles close, lever 34 lifts plunger 23 by means of lever 35 and rod 13 so that fuel is sucked from bowl 20 into the pump barrel through valve 21.

By acting on throttles control lever 29, primary throttle 26 opens up to the stiffening point established by the secondary throat opening indicator mechanism; secondary throttle 32 remains closed. During this first stage of acceleration the pump remains inactive. Subsequently, as secondary throttle 32 is opened, secondary shaft 33 rotates with lever 34 and causes neutral

lever 35 to lower; under the action of spring 14 both rod 13 and plunger 23 travel a given stroke and fuel is injected into primary barrel 1 through duct 4, valve 3 and pump metered jet. 2.

Should it be necessary to adopt a noticeably large diameter drain orifice, valve 21 may be replaced by screw 39 whose orifice performs as inlet and drain port.

Carburetors having barrels of the same diameter have been considered so far, but other carburetors exist, where the diameter of the primary throat is notably smaller than the secondary throat. An example is carburetor DCZC installed as standard equipment on Citroën DS19 cars.

Fig. 49 illustrates how this carburetor incorporates the peculiarity of having a single idle mixture adjusting screw 25 even though there are two idle speed jets. The primary throat idle orifice 32 is fixed, i.e., has no means of adjustment.

Other types of carburetors are those with four barrels and are used mainly for racing cars. Their throttles are controlled by parallel shafts whose rotation is synchronized by a pair of toothed sectors Fig. 50.

Every throat is fitted with a metered orifice 15 for idle operation and every orifice is provided with its own adjusting screw.

No starting device is provided in the four-barrel carburetors (this principle being common to almost all racing engine carburetors).

This particular type of carburetor is provided with additional air intakes in order to increase the velocity of incoming air and with extended auxiliary Venturis having the purpose of dampening the engine aspiration pulsations thus preventing the rejection of mixture at given RPM rates.

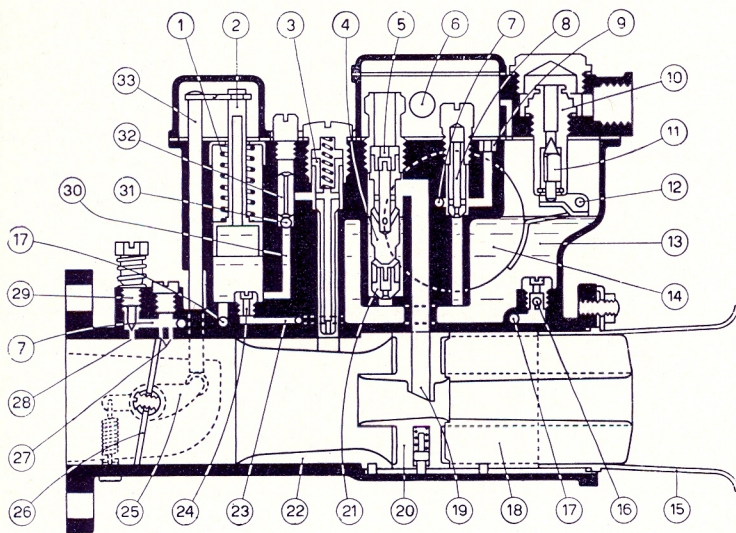

Fig. 51

1. Pump spring - 2. Pump plunger - 3. Pump jet - 4. Emulsion tube - 5. Air corrector jet - 6. Dynamic air intake connection - 7. Idle mixture duct - 8. Idle jet - 9. Idle air bush - 10. Needle valve - 11. Valve needle - 12. Float fulcrum pin - 13. Bowl - 14. Float - 15. Additional air horn - 16. Pump inlet valve - 17. Pump suction duct - 18. Auxiliary Venturi extension - 19. Nozzle - 20. Auxiliary Venturi - 21. Main jet - 22. Primary Venturi - 23. Pump drain duct - 24. Pump drain jet - 25. Pump control lever - 26. Throttle - 27. Transition orifices - 28. Idle orifice to duct - 29. Idle mixture adjustment screw - 30. Pump delivery duct - 31. Ball delivery valve - 32. Ball hold-down - 33. Pump rod.

HIGH SPEED DEVICE

Figs. 39 and 51 show two types of dual-barrel, horizontal carburetors for racing cars. In these carburetors the accelerating pump delivery valve performs also as a high speed device according to this principle: when (see Fig. 51) the vacuum in the carburetor barrels is strong enough to lift hold-down weight 32 and ball 31 from its seat, a given amount of fuel is sucked into the primary barrels through inlet valve 16, ducts 17 and 30, and pump jets 3. This causes an enrichment of the mixture with consequent increased power of the engine. Only when the engine r.p.m. are reduced will the vacuum action of the pump jet become weaker and both valve 31 and hold-down weight 32 will then fall back into their seat through gravity.

In Fig. 39 it is needle 4 which performs as the high speed device. Its operation is still dependent on vacuum, as for the ball valve mentioned above. The

needle weight is calibrated to permit the rising of the needle only at the required RPM rates.

FULL-POWER DEVICE

This device consists — Fig. 52 — of valve 24 and metered jets 20.

For throttle opening positions between 2/3 and total opening, plunger 15 is depressed by spring 9 opening full-power valve 24 and so allows the fuel (metered by jets 20) to flow from the bowl through inlet valve 19 and ducts 21, thus enriching the mixture drawn in by the engine.

A comparison between the high-speed and the full-power devices discloses that the former intervenes only when the vacuum is such as to cause the rising of the pump delivery valve needle while the latter is operative even when the vehicle moves at average or low speeds but with both throttles wide open.

1. Pump jet body - 2. Auxiliary Venturi - 3. Nozzle - 4. Emulsion tube - 5. Air corrector jet - 6. Idle speed jet - 7. Idle air orifice - 8. Pump rod - 9. Pump spring - 10. Float - 11. Needle valve - 12. Valve needle - 13. Float fulcrum pin - 14. Needle delivery valve - 15. Pump plunger - 16. Bowl - 17. Pump duct - 18. Pump drain jet - 19. Pump inlet valve - 20. Full power jet - 21. Full power duct - 22. Main jet - 23. Jet-to-well duct - 24. Full power valve - 25. Pump control lever - 26. Transition orifices - 27. Idle orifice to duct - 28. Throttle - 29. Idle mixture duct - 30. Primary Venturi - 31. Ball delivery valve.

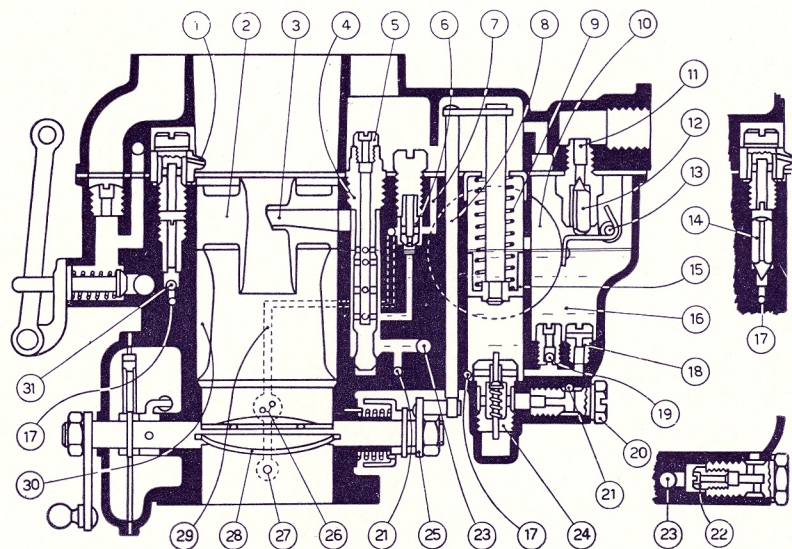

Fig. 52

ANTI-DIESELING DEVICE

Its purpose is that of shutting off the fuel supply to the engine as soon as the ignition is switched off, to prevent the engine from continuing to run by self-ignition due to overheating resulting from prolonged operation under heavy load.

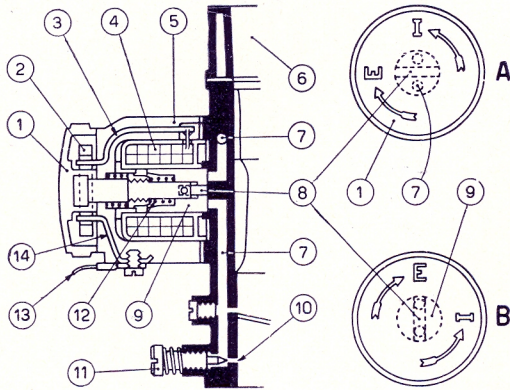

Fig. 53

1. Interceptor control knob - 2. Contact lug - 3. Lamina - 4. Solenoid - 5. Interceptor body - 6. Primary barrel - 7. Idle mixture duct - 8. Communication milling - 9. Plunger - 10. Idling orifice to duct - 11. Idle mixture adjusting screw - 12. Plunger spring - 13. Interceptor connecting terminal - 14. Lamina.

This device — **Fig. 53** — consists of solenoid **4**, spring **12** and knob **1** which, through a suitable rod, controls plunger **9** in which milling **8** is machined. Solenoid **4** is fed by the low-voltage circuit through the ignition switch on the instrument panel by means of laminae **3** and **14**, and finger **2** fixed to knob **1**.

When the device is in operation — **diagram A** — letter **I** — «**inserted**» is turned uppermost and milling **8** is located between the two ports of duct **7**. As the ignition key is inserted in the switch to start the engine, the circuit closes, solenoid **4** is excited and by overcoming the load of spring **12** lifts plunger **9** thus establishing a communication between the two portions of duct **7**. The fuel may thus regularly flow to the cylinders.

When the key is withdrawn to switch off the ignition, the current to solenoid **4** is cut off; the solenoid is demagnetized, plunger **9** retracts under the action of spring **12** and the communication between the two portions of duct **7** is blanked off: the engine stops immediately even if overheated to the point that self-ignition may occur.

Should it be desired to exclude the device, knob **1** must be rotated **90°**, i.e., with letter **E** = **excluded** uppermost (**diagram B**). In this position finger **2** breaks the contact between laminae **3** and **14**, plunger **9** leaves a passage between the two portions of duct **7** via milling **8** and idle mixture flows regularly to the engine.

INDEX

PART ONE

CARBURETOR OPERATION PRINCIPLES

	page
DIAGRAMMATIC ILLUSTRATION OF FUEL SYSTEM	3
FUNDAMENTAL TYPES OF CARBURETORS	3
CONDITIONS OF ENGINE OPERATION	4
TASK OF CARBURETOR - FUEL MIXTURE	4
THE SIMPLE CARBURETOR	4
Operation of the simple carburetor	5
Considerations on simple carburetor operation	5
THE MODERN CARBURETOR - AUTOMATIC CONTROL OF THE AIR/FUEL MIXTURE RATIO	6
Air Correction	6
SLOW RUNNING OR IDLING SPEED DEVICE	7
CHANGE-OVER FROM IDLE SPEED TO POWER OPERATION	7
Progressive acceleration	7
Accelerating pump	8
STARTING DEVICE	9
Starting device of the auxiliary carburetor type	9
Starting device of the choke valve type	10
AUTOMATIC STARTING DEVICE	10
MODERN CARBURETOR FEATURES	10
Auxiliary (or secondary) venturi	10
Full-power device	11
CARBURETORS WITH TWO OR MORE THROATS	11
SELECTING A CARBURETOR	12
EXAMPLES OF APPLICATION	13

PART TWO

CONSTRUCTIONAL FEATURES OF CARBURETORS

	page
BASIC CARBURETOR DEVICES	15
IDLE SPEED AND PROGRESSION CIRCUIT	15
Transition or (progression) orifice	18
MAIN FEED SYSTEM	20
Main jet	21
Main jet holder	21
Emulsion tube	22
Air corrector jet	23
Primary venturi	23
Auxiliary venturi	24
Constant-level system	24
STARTING DEVICE (STARTER)	25
Auxiliary carburetor systems	25
a) plain valve starting device	25
b) Economy-Super-Aspiration (E.S.A.)	26
c) progressive action starting devices	27
Strangler throttle (choke) type starting devices	28
ACCELERATING PUMP	29
DUAL-BARREL CARBURETORS	31
HIGH SPEED DEVICE	35
FULL-POWER DEVICE	35
ANTI-DIESELING DEVICE	36

EDUARDO WEBER S. P. A. FABBRICA ITALIANA CARBURATORI
Registered office: MILAN - Works: via Timavo 33, BOLOGNA (Italy)
Cable address: WEBER - BOLOGNA - Telephone 41.79.95
Telex 5119 WEBER BO